

# BID ADVERTISEMENT FOR THE WEEKS OF

May 20, 2026 & May 27, 2026

## BID OPENS - THURSDAY JUNE 18, 2026

**FILE NO. 56-26 Valves and Appurtenances 20 inch and Larger Re-Bid**

FOR THE DIVISION OF WATER FOR THE DEPARTMENT OF PUBLIC UTILITIES AS AUTHORIZED BY ORDINANCE 129.25. PASSED BY COUNCIL SEPTEMBER 21, 1992.

There will be a **NON MANDATORY Pre-Bid Meeting**, Thursday, May 28, 2026 at 2:30 pm., Via Microsoft Teams, To call into meeting dial in 1-929-352-1743, Access Code 481 838 453#.

**Note:** Bid must be delivered to the Office of the Commissioner of Purchases and Supplies, Cleveland City Hall, 601 Lakeside Avenue, Room 128, Cleveland, Ohio 44114 before 12 o'clock noon (Eastern Time).



---

**CITY OF CLEVELAND,  
OHIO**

**DEPARTMENT OF FINANCE**



**DIVISION OF PURCHASES AND SUPPLIES**

**INVITATION TO BID**

---

**INVITATION TO BID AND FORMAL BID PACKAGE  
TABLE OF CONTENTS**

<u>ITEMS</u>	<u>SEQUENCE ORDER NUMBER</u>
Authorizing Ordinance.....	1
Bidder's Checklist.....	2
Instructions to Bidders (Part A).....	3
W-9 Form .....	4
Vendor Information Form .....	5
Bidder's Affidavit .....	6
Bid Bond .....	7
Bid Form .....	8
Bid Schedule of Items (Price Sheets).....	9
General Conditions (Part B) .....	10
Specifications/Description of Products and/or Services (Supplemental Sections C, D, etc.) .....	11
Nothern Ireland Form .....	12
Prevailing Wage, Davis Beacon or Living Wage (If applicable).....	13
Fannie M. Lewis, Chapter 188 (If applicable) .....	14
Office of Equal Opportunity Notice to Bidders, Chapter 187 .....	15
Office of Equal Opportunity Clause .....	16
OEO Participation Form .....	17
OEO Schedules Checklist .....	18
OEO Schedules 1- 4 .....	19
Subcontracting Participation or Waiver Form.....	20
OEO Submission Schedule .....	21

CITY OF CLEVELAND  
Department of Finance  
Division of Purchases and Supplies  
City Hall, Room 128  
Cleveland, Ohio 44114  
216-664-2620

## **129.25 Purchase of Water System Maintenance Equipment**

The Director of Public Utilities is authorized to enter into one or more standard purchase or requirement contracts duly let to the lowest and best bidder after competitive bidding for Water system maintenance equipment deemed by the Director of Public Utilities to be necessary to the operations of the Division of Water, including, but not limited to: meters and meter parts; manhole covers, rings, and manholes; ductile iron pipe and fittings; copper pipe and tubing; parts for pumps, engines and saws; service fittings and pipe couplings; lining cement, mortar cement and sand; valves, valve boxes, and appurtenances; bypass piping, fittings and valves; fire hydrants and fire hydrant parts; pipe repair clamps; and stop cock boxes. Any purchase made pursuant to this section shall be made by the Commissioner of Purchases and Supplies and paid from the annual appropriations made for such purpose.

(Ord. No. 1630-92. Passed 9-21-92, eff. 9-25-92)

# City of Cleveland

DEPARTMENT OF FINANCE  
PAUL C. BARRETT  
DIRECTOR



DIVISION OF PURCHASES AND SUPPLIES  
TIFFANY JOHNSON  
COMMISSIONER

## BIDDER'S CHECK LIST

*The City of Cleveland requires that each bid submitted must comply with certain legal requirements to be considered a valid and formal bid. The checklist below is provided to assist in avoiding rejection of your bid due to omission of required information or forms.*

### CHECK WHEN COMPLETED

#### A. Bid/Schedule of Items

- 1. Is (are) the bid page(s) completed as required **and** signed in the upper right-hand corner?
- 2. Are all prices (whether Unit, or Gross and extensions) clearly and accurately presented?
- 3. Is the delivery time stated? Is the payment discount given?

#### B. Bid Bond

- 1. Is the bond made out in the names of and signed by both the principal **and** surety?
- 2. Is the bond amount sufficient for the amount of the bid?
- 3. Is there a power of attorney attached to the bond?

#### C. Bid Check (if submitted in lieu of Bid Bond)

- 1. Is the check in an amount sufficient for the amount of the bid?
- 2. Is the check either properly certified or a cashier's check?
- 3. Is the Check made payable to: THE CITY OF CLEVELAND?

#### D. Bid Form (not to be confused with the Bid Bond)

- 1. Is all the required information given?
- 2. Is the form signed?

#### E. Affidavit

- 1. Does the affidavit contain all the information required ON BOTH SIDES?
- 2. Is it properly Signed? Is it properly notarized by a Notary Public?

#### F. Contract Compliance Certifications for Bid Consideration

- 1. Do you have questions about a contract compliance certification number or a CSB/ minority/female business enterprise certification number, contact the Office of the Director of Equal Opportunity for further information (Phone 216/664-4152).
- 2. Is your contract compliance certification certificate, statement of deemed compliance, or an application for certification included in the bid?
- 3. If you are a Minority/Female/Cleveland Small Business Enterprise and or Local Producer/ Local Sustainable Business, do you include your MBE/FBE/LPE/SUBE certification certificate, or a completed application therein?
- 4. Did you read and complete OEO Schedules 1-4? Did you include signed Schedule 3's from all certified subcontractors?

#### G. Bid Envelope

- 1. Is the envelope identified with the correct title of the bid and the due date?
- 2. Is the envelope securely sealed?

#### H. Performance Bond

- 1. Will you be able to furnish the required Performance Bond referred to in paragraph A-8 of INSTRUCTIONS TO BIDDERS, and/or in paragraph B-8 of General Conditions?
- 2. Notice: A certified or cashier's check is not acceptable in lieu of a Performance Bond!

**I. Federal Tax ID Form**

- \_\_\_ 1. Is all the required information given?
- \_\_\_ 2. Is the form signed?

**J. Northern Ireland Fair Employment Practices Disclosure**

- \_\_\_ 1. Is all the required information given?
- \_\_\_ 2. Is the form signed?

**K. Project Plan**

- \_\_\_ 1. Is all the required information given?

**L. Contractor Qualifications**

- \_\_\_ 1. Is all the required information given if requested?

**M. Additional Information:**

- \_\_\_ 1. **Wage Theft and Payroll Fraud Disclosure**  
Is the form signed and returned?
  
- \_\_\_ 2. **Project Labor Agreement (If included in the invitation to bid)**

**Because of the large variety of commodities, services and improvements required by the City, additional information is often requested in a format not listed above. In such a case, please review your bid carefully to verify that you have accurately and completely supplied all such data. Should you have any questions, please call the Division of Purchases and Supplies (216/664-2620) for clarifications**

## INSTRUCTIONS TO BIDDERS

### A-1 INVITATION TO BID

Sealed bids endorsed as designated in the "Title of Bid" section of the bid sheet(s) will be received at the Office of the Commissioner of Purchases and Supplies, Room 128, Cleveland City Hall, Cleveland, Ohio 44114, until 12:00 o'clock noon, official time, on the date indicated in the "Bid Opening" section of Page 1 of the bid page(s) and thereafter will be publicly opened and read in Room 128.

### A-2 FORM OF BID (BID FORM)

- a. Every bid must be made upon the blank form of bid attached hereto.
- b. Each bid must be clearly signed with the full name and address of every person, firm or corporation interested in such bid, followed by the date of such signing, in the space provided at the bottom of the bid form. If more than one person, firm or corporation has an interest in such bid, then the full name and address of each person, firm or corporation must be clearly signed on said bid. If the bidder is a partnership, the firm name and address, as well as the name and address of each individual partner must be given. If the bidder is a corporation, the name of the corporation, the name and title of the officer duly authorize to sign for the corporation, the business address of such officer and the name of the state in which the corporation is incorporated must be given.
- c. The bidder shall insert the amount of the bid bond, certified check or cashier's check in the space provided in the bid form.
- d. The bidder agrees to be bound by his bid from the time the bid is submitted until the earlier of the date stipulated by such bidder or the fourth regular meeting of the Board of Control after the bid submission date unless such time is extended by agreement between the bidder and the Board.

### A-3 BIDDERS AFFIDAVIT

Each bidder shall submit with its bid an affidavit stating that neither it nor its agents, nor any other party for it has paid or agreed to pay, directly or indirectly, any person, firm or corporation any money or valuable consideration for assistance in procuring or attempting to procure the contract herein referred to, and further stating that no such money or reward will be hereafter paid. This affidavit must be on the form which is hereto attached.

### A-4 BID BOND: CERTIFIED OR CASHIER'S CHECK

Each bid shall be accompanied by a bid bond signed by a surety company authorized to do business in Ohio, or by a cashier's check or certified check on a solvent bank, which bond or check shall be in the sum of five percent (5%) of the amount of the bid, except that with bids for purchase contracts not in excess of Fifty Thousand Dollars (\$50,000). Said bond or check shall be given as security that if the bid is accepted a contract will be entered into and the performance of it properly secured.

**A-5 DISPOSITION OF BID BOND, CERTIFIED OR CASHIER'S CHECK**

- a. When the bid is accepted, the bid bond, certified or cashier's check will be returned after the contract has been signed and the performance bond, if required, has been submitted to, and approved by, the City.
- b. If the successful bidder fails to enter into a contract, the bid bond, certified or cashier's check shall be forfeited and the principal amount of the bid bond shall be paid to the City, or the check shall be surrendered to the City as the agreed amount of liquidated damages.
- c. The bid bond, certified or cashier's check of the next lowest and best bidder will be retained until the lowest and best bidder has signed and secured the performance of its contract. If such lowest and best bidder fails to do so, the security of the next lowest and best bidder shall continue to be retained until it properly secures the contract awarded it. If such next lowest and best bidder defaults, the principal amount of its bid bond, or check shall also be forfeited to the City as liquidated damages.
- d. When a bid is rejected, the bid bond or check will be released or returned, respectively, to the bidder.

**A-6 EXPLANATIONS WRITTEN OR ORAL**

Any bidder finding a discrepancy or omission in the specifications or having any doubt as to their meaning, shall immediately notify the Commissioner of Purchases and Supplies, in writing. The Commissioner will respond by sending written notices or instructions to all bidders. The City will not be responsible for any oral instructions.

**A-7 PRICE BIDS AND DISCOUNTS**

- a. **Unit Prices**  
In the Schedule of Items the bidder must give the unit price stated in figures of every item bid, in the space so provided.
- b. **Trade Discounts**  
When the bidder offers a trade discount, the amount of such discount shall be stated on the Schedule of Items bid.
- c. **Catalog Pricing**  
Where the bidder submits its quotation by filing its catalog price list and discount, such documents shall be part of the bid and must be separately signed by the same person and in the same manner as on the bid form.

**A-8 BIDDER'S DESCRIPTION OF ITEMS**

- a. Each bidder shall, in its bid, describe completely the goods or services it proposes to furnish in response to and under the terms of the bid.
- b. The Commissioner of Purchases and Supplies may require a bidder to furnish additional information and/or specifications concerning items to be purchased under the terms of the bid.

**A-9 MANUFACTURER'S NAME**

- a. The use of a manufacturer's or a trade name in the specifications is solely for the purpose of designating a standard of quality and type and for no other purpose.
- b. Every bidder shall state in its Schedule of Items bid the manufacturer's and the trade name, if any, of each item they propose to furnish.

**A-10 SAMPLES**

If the commissioner of Purchases and Supplies requests, a bidder shall provide samples of the items it proposes to furnish if awarded a contract pursuant to its bid.

**A-11 TIME OF DELIVERY**

Bidder must state in its bid the time, in calendar days, within which it will deliver the item(s) bid unless stated differently in the specifications.

**A-12 PAYMENT DISCOUNT WHEN USED TO DETERMINE LOWEST AND BEST BID**

- a. In determining the lowest and best bid, the City will consider all bids on a basis of the net price to be paid after deduction of the discount specified; except that if the terms of payment specified by the bidder require payment in less than thirty (30) days from the date of the invoice, the discount offered will not be deducted from the price stated in the bid to determine the lowest and best bidder, and the bid will be considered only on the basis of the unit price actually named in the bid. But if, notwithstanding the provisions of this paragraph such bid is determined to be the lowest and best bid, the City reserves the right to accept the terms named in the bid if such terms are to the advantage of the City as a basis for payment of invoices only, but not in any case as a basis for determining the lowest and best bidder.
- b. The City will take a discount of two percent (2%) on payments made within thirty (30) days from receipt of articles, commodities, materials, supplies, equipment or services, unless the bidder indicates otherwise on the space provided on the Schedule of Items bid.

**PARAGRAPHS A-13 THROUGH A-15 APPLY ONLY IF THE "REQUIREMENT CONTRACT" BLOCK IS CHECKED ON PAGE 1 OF THE *SCHEDULE OF ITEMS* AND ON THE *BID FORM*.**

**A-13 REQUIREMENT CONTRACT DEFINED**

- a. A requirement contract is a contract under which the contractor has a duty to provide the City's requirements during the contract term for all articles, commodities, supplies, materials, equipment and/or services set forth in the bid and required by the City's authorized users of the items approved for contract.
- b. A contract awarded under this bid will be termed a requirement contract.

**A-14 PURCHASES UNDER A REQUIREMENT CONTRACT**

- a. Under a requirement contract, a contractor shall supply all the City's requirements during the term for the articles, commodities, supplies, materials, services or equipment set forth in the *Invitation to Bid*. See GENERAL CONDITIONS, Section B-24, **Duration of Contract**.
- b. If the *Schedule of Items* in the *Invitation to Bid* is marked "requirement contract," then all quantities stated in the *Schedule of Items* are the City's good-faith estimates only. The City shall place each order under the

contract, whether singly or cumulatively more or less than the estimated quantities set forth in the *Schedule of Items*, by a Delivery Order against the contract and separately certified.

**A-15 LIMITATION OF PERIOD OF CONTRACT**

If the proposed duration of the contract would deprive the City of the best available market price, the bidder may offer an alternate bid as to duration of the contract, setting forth in the bid the longest period of time it can furnish and deliver the proportionate amount of items at the firm price set forth in the bid. No other provision of the Invitation to Bid shall be subject to an alternate bid unless specifically requested.

**A-16 BID DISCOUNTS - APPLICABLE TO BIDS FOR GOODS AND SERVICES PURCHASE CONTRACTS AND PUBLIC IMPROVEMENT CONTRACTS IN EXCESS OF FIFTY THOUSAND DOLLARS (\$50,000).**

a. Bid Discounts under Sections 187.03 and 187.05. If the bid of any prime contractor that is a CSB, MBE, FBE or a CSB, MBE or FBE joint venture is no more than five percent (5%) higher than the lowest actual bid for a contract that is not from a CSB, MBE, FBE or a CSB, MBE or FBE joint venture, the contracting department shall apply a Bid Discount of five percent (5%) to the CSB, MBE, FBE or CSB, MBE or FBE joint venture bid for the purpose of establishing a Comparison Bid. The City of Cleveland shall use the following ranking in determining who receives the preference:

1. Where the disparity study has determined that a disparity exists, the bid discount shall go to the bidders who are certified by the City as members of the specific MBE/FBE group for which the proven disparity exists. No other bidders shall receive any preference under Sections 187.03 and 187.05 at the prime contractor level.
2. Where no disparity has been proven, or when no bids are received from groups for which a proven disparity exists, the bid discount shall go to certified CSB bidders certified by the City as located within the city limits of Cleveland. No other bidders shall receive any preference under Sections 187.03 and 187.05 at the prime contractor level.
3. Where no disparity has been proven, or when no bids are received from groups for which a proven disparity exists, and no bids were received from certified CSB firms certified by the City as located within the city limits of Cleveland, the bid discount shall go to Certified CSB bidders certified by the City as located within Cuyahoga County. No other bidders shall receive any preference under Sections 187.03 and 187.05 at the prime contractor level.
4. In addition to any bid discounts at the prime contractor level, all prime contractors shall receive a bid discount of 5% of the total dollar amount of all CSB, MBE and/or FBE certified by the City that the prime contractor properly documents as subcontractors in their bid, for the purpose of establishing a Comparison Bid.
5. The total Bid Discount awarded to any bidder on a bid pursuant to Sections 187.03 and 187.05 shall not exceed \$50,000.00.

**b. Bid Discounts under Section 187A.02(a):** Application of Bid Discount - A Contracting Department shall apply a Bid Discount of two percent (2%) to a bid received from a Local Producer (LPE); two percent (2%) to a bid received from a Local Food-Producer (LPE); and two percent (2%) to a bid received from a Local Sustainable Business (SUBE); provided that the maximum total Bid Discount applied under Section 187A.02 (a) shall not exceed four percent (4%). Bid Discounts applied under Section 187A.02 (a) shall be in addition to any Bid Discount applied under Sections 187.03 and 187.05. The maximum amount of any Bid Discounts applied under this Section 187A.02 (a) shall not exceed \$50,000.

**c. Maximum Cumulative Amount of All Bid Discounts:**

The maximum cumulative amount of all Bid Discounts that may be applied to the bid under Sections 187.03, 187.05, and 187A.02 shall not exceed \$75,000.00, or nine percent (9%), whichever is lower.

**d. Comparison Bid to Determine Lowest and Best Bidder:**

The City shall determine the Comparison Bid by totaling all applicable Bid Discounts under Sections 187.03, 187.05, and 187A.02. The City shall use the Comparison Bid in determining the lowest and best or lowest responsible bidder for the purpose of awarding the contract. If more than one CSB, MBE, FBE, LPE, SUBE or CSB, MBE, FBE LPE, SUBE joint venture prime contractor in the respective category submits a bid that is no more than five percent (5%) higher than the lowest actual bid that is not from a CSB, MBE, FBE, LPE, SUBE or from a CSB, MBE, FBE, LPE, SUBE joint venture, the contracting department shall recommend the CSB, MBE, FBE, LPE, SUBE, or CSB, MBE, FBE, LPE, SUBE joint venture submitting the lowest bid, after the inclusion of all applicable prime and subcontractor discounts, as the lowest and best or lowest responsible bidder.

The City shall use the Comparison Bid amount determined by applying the bid discounts described in Articles A-16A, and A-16B, above for evaluation purposes only; the City shall use the actual bid amount for the purposes of bid approval and contract award.

**e. City of Cleveland Certification required:** For the purpose of determining a bidder's eligibility for bid discounts, the City shall only consider bidders with valid certificates issued by the City of Cleveland's Office of Equal Opportunity. The certifications must be active on the date and time of the deadline for bid submission. Expired certification holders and pending certifications cannot be considered for calculation of bid discounts. Certifications from other public or private entities cannot be considered.

**A-17 Good Faith Participation - APPLICABLE TO BIDS FOR GOODS AND SERVICES PURCHASE CONTRACTS AND PUBLIC IMPROVEMENT CONTRACTS IN EXCESS OF FIFTY THOUSAND DOLLARS (\$50,000).**

Bidders are required to actively participate and demonstrate good faith in attempting to meet all OEO goals for this procurement. A good faith effort to meet certified CSB, MBE, and/or FBE subcontractor participation goals as established in this contract is of the essence of the contract.

Good faith participation shall include:

1. Active cooperation in making and documenting a serious effort to gain and maintain participation from certified businesses at or above the specific goals set for this procurement;
2. Achieving or exceeding the CSB/MBE/FBE goals set for this particular procurement and/or documenting the practical steps taken by the bidder in attempting to comply;
3. Active attendance and participation in all prebid meetings, Notice to Proceed meetings, and progress meetings during the contract;
4. Active compliance and cooperation with Project Monitors from OEO and/or the Department; and,
5. Timely and accurate submittals of all required forms, including, but not limited to, electronic monitoring forms, employment reports and certified payrolls if applicable.

The final determination of good faith effort shall be made by the Office of Equal Opportunity based upon each bidder's actions as documented in the required forms and as verified by OEO follow up.

**A-18 Cleveland Area Business Code Notice to Bidders & Schedules - APPLICABLE TO BIDS FOR GOODS AND SERVICES PURCHASE CONTRACTS AND PUBLIC IMPROVEMENT CONTRACTS IN EXCESS OF FIFTY THOUSAND DOLLARS (\$50,000).**

Sections 187 and 187A of the Codified Ordinances of the City of Cleveland Ohio, the Cleveland Area Business Code, in its entirety, whether reproduced in whole or in part within these documents, as well as the Cleveland Area Business Code Notice to Bidders & Schedules included in this bid document, shall become part of any contract awarded pursuant to this Invitation to Bid. Compliance with Section 187 and 187A is of the essence of the contract.

**A-19 SUBCONTRACTING:**

a. Any and all proposed subcontractors, whether City certified or not, must be divulged and listed in the sealed bid. Include all proposed subcontractors on OEO Schedule 2. A Schedule 3 is also required for each proposed subcontractor that is CSB, MBE, FBE, LPE, or SUBE certified. However, a Schedule 3 is not required for proposed subcontractors who are not City-certified as a CSB, MBE, FBE, LPE, or SUBE.

b. If OEO Schedule 2 is not included in the bid documents, you must submit a proposed subcontractor list on a separate, signed sheet of paper, listing the name, address, type of work or materials, and total subcontractor amount for each and every subcontractor that you propose to use on the contract.

c. All proposed subcontractors listed in your bid must receive written Board of Control approval in advance. The subcontractors you propose in your sealed bid will be considered the subcontractors that you will use in the contract if awarded to you. See Article B-11 regarding the City's Sub-contractor Addition and Substitution Policy and Procedure. The City also reserves the right to approve an award, but not approve a proposed subcontractor.

d. The City maintains a list of Vendors Ineligible to Contract or Subcontract with the City at the City of Cleveland website: <http://www.city.cleveland.oh.us>. It is each bidder's responsibility to propose only eligible contractors. The City cannot approve a subcontractor whose name appears in this listing.



must obtain your correct taxpayer identification number (TIN), which may be your social security number (SSN), individual taxpayer identification number (ITIN), adoption taxpayer identification number (ATIN), or employer identification number (EIN), to report on an information return the amount paid to you, or other amount reportable on an information return. Examples of information returns include, but are not limited to, the following.

- Form 1099-INT (interest earned or paid).
- Form 1099-DIV (dividends, including those from stocks or mutual funds).
- Form 1099-MISC (various types of income, prizes, awards, or gross proceeds).
- Form 1099-NEC (nonemployee compensation).
- Form 1099-B (stock or mutual fund sales and certain other transactions by brokers).
- Form 1099-S (proceeds from real estate transactions).
- Form 1099-K (merchant card and third-party network transactions).
- Form 1098 (home mortgage interest), 1098-E (student loan interest), and 1098-T (tuition).
- Form 1099-C (canceled debt).
- Form 1099-A (acquisition or abandonment of secured property).

Use Form W-9 only if you are a U.S. person (including a resident alien), to provide your correct TIN.

**Caution:** If you don't return Form W-9 to the requester with a TIN, you might be subject to backup withholding. See *What is backup withholding*, later.

**By signing the filled-out form, you:**

1. Certify that the TIN you are giving is correct (or you are waiting for a number to be issued);
2. Certify that you are not subject to backup withholding; or
3. Claim exemption from backup withholding if you are a U.S. exempt payee; and
4. Certify to your non-foreign status for purposes of withholding under chapter 3 or 4 of the Code (if applicable); and
5. Certify that FATCA code(s) entered on this form (if any) indicating that you are exempt from the FATCA reporting is correct. See *What Is FATCA Reporting*, later, for further information.

**Note:** If you are a U.S. person and a requester gives you a form other than Form W-9 to request your TIN, you must use the requester's form if it is substantially similar to this Form W-9.

**Definition of a U.S. person.** For federal tax purposes, you are considered a U.S. person if you are:

- An individual who is a U.S. citizen or U.S. resident alien;
- A partnership, corporation, company, or association created or organized in the United States or under the laws of the United States;
- An estate (other than a foreign estate); or
- A domestic trust (as defined in Regulations section 301.7701-7).

**Establishing U.S. status for purposes of chapter 3 and chapter 4 withholding.** Payments made to foreign persons, including certain distributions, allocations of income, or transfers of sales proceeds, may be subject to withholding under chapter 3 or chapter 4 of the Code (sections 1441-1474). Under those rules, if a Form W-9 or other certification of non-foreign status has not been received, a withholding agent, transferee, or partnership (payor) generally applies presumption rules that may require the payor to withhold applicable tax from the recipient, owner, transferor, or partner (payee). See Pub. 515, *Withholding of Tax on Nonresident Aliens and Foreign Entities*.

The following persons must provide Form W-9 to the payor for purposes of establishing its non-foreign status.

- In the case of a disregarded entity with a U.S. owner, the U.S. owner of the disregarded entity and not the disregarded entity.
- In the case of a grantor trust with a U.S. grantor or other U.S. owner, generally, the U.S. grantor or other U.S. owner of the grantor trust and not the grantor trust.
- In the case of a U.S. trust (other than a grantor trust), the U.S. trust and not the beneficiaries of the trust.

See Pub. 515 for more information on providing a Form W-9 or a certification of non-foreign status to avoid withholding.

**Foreign person.** If you are a foreign person or the U.S. branch of a foreign bank that has elected to be treated as a U.S. person (under Regulations section 1.1441-1(b)(2)(iv) or other applicable section for chapter 3 or 4 purposes), do not use Form W-9. Instead, use the appropriate Form W-8 or Form 8233 (see Pub. 515). If you are a qualified foreign pension fund under Regulations section 1.897(i)-1(d), or a partnership that is wholly owned by qualified foreign pension funds, that is treated as a non-foreign person for purposes of section 1445 withholding, do not use Form W-9. Instead, use Form W-BEXP (or other certification of non-foreign status).

**Nonresident alien who becomes a resident alien.** Generally, only a nonresident alien individual may use the terms of a tax treaty to reduce or eliminate U.S. tax on certain types of income. However, most tax treaties contain a provision known as a saving clause. Exceptions specified in the saving clause may permit an exemption from tax to continue for certain types of income even after the payee has otherwise become a U.S. resident alien for tax purposes.

If you are a U.S. resident alien who is relying on an exception contained in the saving clause of a tax treaty to claim an exemption from U.S. tax on certain types of income, you must attach a statement to Form W-9 that specifies the following five items.

1. The treaty country. Generally, this must be the same treaty under which you claimed exemption from tax as a nonresident alien.
2. The treaty article addressing the income.
3. The article number (or location) in the tax treaty that contains the saving clause and its exceptions.
4. The type and amount of income that qualifies for the exemption from tax.
5. Sufficient facts to justify the exemption from tax under the terms of the treaty article.

**Example.** Article 20 of the U.S.-China income tax treaty allows an exemption from tax for scholarship income received by a Chinese student temporarily present in the United States. Under U.S. law, this student will become a resident alien for tax purposes if their stay in the United States exceeds 5 calendar years. However, paragraph 2 of the first Protocol to the U.S.-China treaty (dated April 30, 1984) allows the provisions of Article 20 to continue to apply even after the Chinese student becomes a resident alien of the United States. A Chinese student who qualifies for this exception (under paragraph 2 of the first Protocol) and is relying on this exception to claim an exemption from tax on their scholarship or fellowship income would attach to Form W-9 a statement that includes the information described above to support that exemption.

If you are a nonresident alien or a foreign entity, give the requester the appropriate completed Form W-8 or Form 8233.

## Backup Withholding

**What is backup withholding?** Persons making certain payments to you must under certain conditions withhold and pay to the IRS 24% of such payments. This is called "backup withholding." Payments that may be subject to backup withholding include, but are not limited to, interest, tax-exempt interest, dividends, broker and barter exchange transactions, rents, royalties, nonemployee pay, payments made in settlement of payment card and third-party network transactions, and certain payments from fishing boat operators. Real estate transactions are not subject to backup withholding.

You will not be subject to backup withholding on payments you receive if you give the requester your correct TIN, make the proper certifications, and report all your taxable interest and dividends on your tax return.

**Payments you receive will be subject to backup withholding if:**

1. You do not furnish your TIN to the requester;
2. You do not certify your TIN when required (see the instructions for Part II for details);
3. The IRS tells the requester that you furnished an incorrect TIN;
4. The IRS tells you that you are subject to backup withholding because you did not report all your interest and dividends on your tax return (for reportable interest and dividends only); or
5. You do not certify to the requester that you are not subject to backup withholding, as described in item 4 under "By signing the filled-out form" above (for reportable interest and dividend accounts opened after 1983 only).

Certain payees and payments are exempt from backup withholding. See *Exempt payee code*, later, and the separate Instructions for the Requester of Form W-9 for more information.

See also *Establishing U.S. status for purposes of chapter 3 and chapter 4 withholding*, earlier.

## What Is FATCA Reporting?

The Foreign Account Tax Compliance Act (FATCA) requires a participating foreign financial institution to report all U.S. account holders that are specified U.S. persons. Certain payees are exempt from FATCA reporting. See *Exemption from FATCA reporting code*, later, and the Instructions for the Requester of Form W-9 for more information.

## Updating Your Information

You must provide updated information to any person to whom you claimed to be an exempt payee if you are no longer an exempt payee and anticipate receiving reportable payments in the future from this person. For example, you may need to provide updated information if you are a C corporation that elects to be an S corporation, or if you are no longer tax exempt. In addition, you must furnish a new Form W-9 if the name or TIN changes for the account, for example, if the grantor of a grantor trust dies.

## Penalties

**Failure to furnish TIN.** If you fail to furnish your correct TIN to a requester, you are subject to a penalty of \$50 for each such failure unless your failure is due to reasonable cause and not to willful neglect.

**Civil penalty for false information with respect to withholding.** If you make a false statement with no reasonable basis that results in no backup withholding, you are subject to a \$500 penalty.

**Criminal penalty for falsifying information.** Willfully falsifying certifications or affirmations may subject you to criminal penalties including fines and/or imprisonment.

**Misuse of TINs.** If the requester discloses or uses TINs in violation of federal law, the requester may be subject to civil and criminal penalties.

## Specific Instructions

### Line 1

You must enter one of the following on this line; do not leave this line blank. The name should match the name on your tax return.

If this Form W-9 is for a joint account (other than an account maintained by a foreign financial institution (FFI)), list first, and then circle, the name of the person or entity whose number you entered in Part I of Form W-9. If you are providing Form W-9 to an FFI to document a joint account, each holder of the account that is a U.S. person must provide a Form W-9.

- **Individual.** Generally, enter the name shown on your tax return. If you have changed your last name without informing the Social Security Administration (SSA) of the name change, enter your first name, the last name as shown on your social security card, and your new last name.

**Note for ITIN applicant:** Enter your individual name as it was entered on your Form W-7 application, line 1a. This should also be the same as the name you entered on the Form 1040 you filed with your application.

- **Sole proprietor.** Enter your individual name as shown on your Form 1040 on line 1. Enter your business, trade, or "doing business as" (DBA) name on line 2.

- **Partnership, C corporation, S corporation, or LLC, other than a disregarded entity.** Enter the entity's name as shown on the entity's tax return on line 1 and any business, trade, or DBA name on line 2.

- **Other entities.** Enter your name as shown on required U.S. federal tax documents on line 1. This name should match the name shown on the charter or other legal document creating the entity. Enter any business, trade, or DBA name on line 2.

- **Disregarded entity.** In general, a business entity that has a single owner, including an LLC, and is not a corporation, is disregarded as an entity separate from its owner (a disregarded entity). See Regulations section 301.7701-2(c)(2). A disregarded entity should check the appropriate box for the tax classification of its owner. Enter the owner's name on line 1. The name of the owner entered on line 1 should never be a disregarded entity. The name on line 1 should be the name shown on the income tax return on which the income should be reported. For

example, if a foreign LLC that is treated as a disregarded entity for U.S. federal tax purposes has a single owner that is a U.S. person, the U.S. owner's name is required to be provided on line 1. If the direct owner of the entity is also a disregarded entity, enter the first owner that is not disregarded for federal tax purposes. Enter the disregarded entity's name on line 2. If the owner of the disregarded entity is a foreign person, the owner must complete an appropriate Form W-8 instead of a Form W-9. This is the case even if the foreign person has a U.S. TIN.

### Line 2

If you have a business name, trade name, DBA name, or disregarded entity name, enter it on line 2.

### Line 3a

Check the appropriate box on line 3a for the U.S. federal tax classification of the person whose name is entered on line 1. Check only one box on line 3a.

IF the entity/individual on line 1 is a(n) . . .	THEN check the box for . . .
• Corporation	Corporation.
• Individual or • Sole proprietorship	Individual/sole proprietor.
• LLC classified as a partnership for U.S. federal tax purposes or • LLC that has filed Form 8832 or 2553 electing to be taxed as a corporation	Limited liability company and enter the appropriate tax classification: P = Partnership, C = C corporation, or S = S corporation.
• Partnership	Partnership.
• Trust/estate	Trust/estate.

### Line 3b

Check this box if you are a partnership (including an LLC classified as a partnership for U.S. federal tax purposes), trust, or estate that has any foreign partners, owners, or beneficiaries, and you are providing this form to a partnership, trust, or estate, in which you have an ownership interest. You must check the box on line 3b if you receive a Form W-8 (or documentary evidence) from any partner, owner, or beneficiary establishing foreign status or if you receive a Form W-9 from any partner, owner, or beneficiary that has checked the box on line 3b.

**Note:** A partnership that provides a Form W-9 and checks box 3b may be required to complete Schedules K-2 and K-3 (Form 1065). For more information, see the Partnership Instructions for Schedules K-2 and K-3 (Form 1065).

If you are required to complete line 3b but fail to do so, you may not receive the information necessary to file a correct information return with the IRS or furnish a correct payee statement to your partners or beneficiaries. See, for example, sections 6698, 6722, and 6724 for penalties that may apply.

### Line 4 Exemptions

If you are exempt from backup withholding and/or FATCA reporting, enter in the appropriate space on line 4 any code(s) that may apply to you.

#### Exempt payee code.

- Generally, individuals (including sole proprietors) are not exempt from backup withholding.
- Except as provided below, corporations are exempt from backup withholding for certain payments, including interest and dividends.
- Corporations are not exempt from backup withholding for payments made in settlement of payment card or third-party network transactions.
- Corporations are not exempt from backup withholding with respect to attorneys' fees or gross proceeds paid to attorneys, and corporations that provide medical or health care services are not exempt with respect to payments reportable on Form 1099-MISC.

The following codes identify payees that are exempt from backup withholding. Enter the appropriate code in the space on line 4.

1—An organization exempt from tax under section 501(a), any IRA, or a custodial account under section 403(b)(7) if the account satisfies the requirements of section 401(f)(2).

- 2—The United States or any of its agencies or instrumentalities.
- 3—A state, the District of Columbia, a U.S. commonwealth or territory, or any of their political subdivisions or instrumentalities.
- 4—A foreign government or any of its political subdivisions, agencies, or instrumentalities.
- 5—A corporation.
- 6—A dealer in securities or commodities required to register in the United States, the District of Columbia, or a U.S. commonwealth or territory.
- 7—A futures commission merchant registered with the Commodity Futures Trading Commission.
- 8—A real estate investment trust.
- 9—An entity registered at all times during the tax year under the Investment Company Act of 1940.
- 10—A common trust fund operated by a bank under section 584(a).
- 11—A financial institution as defined under section 581.
- 12—A middleman known in the investment community as a nominee or custodian.
- 13—A trust exempt from tax under section 664 or described in section 4947.

The following chart shows types of payments that may be exempt from backup withholding. The chart applies to the exempt payees listed above, 1 through 13.

IF the payment is for . . .	THEN the payment is exempt for . . .
• Interest and dividend payments	All exempt payees except for 7.
• Broker transactions	Exempt payees 1 through 4 and 6 through 11 and all C corporations. S corporations must not enter an exempt payee code because they are exempt only for sales of noncovered securities acquired prior to 2012.
• Barter exchange transactions and patronage dividends	Exempt payees 1 through 4.
• Payments over \$600 required to be reported and direct sales over \$5,000 <sup>1</sup>	Generally, exempt payees 1 through 5. <sup>2</sup>
• Payments made in settlement of payment card or third-party network transactions	Exempt payees 1 through 4.

<sup>1</sup> See Form 1099-MISC, Miscellaneous Information, and its instructions.

<sup>2</sup> However, the following payments made to a corporation and reportable on Form 1099-MISC are not exempt from backup withholding: medical and health care payments, attorneys' fees, gross proceeds paid to an attorney reportable under section 6045(f), and payments for services paid by a federal executive agency.

**Exemption from FATCA reporting code.** The following codes identify payees that are exempt from reporting under FATCA. These codes apply to persons submitting this form for accounts maintained outside of the United States by certain foreign financial institutions. Therefore, if you are only submitting this form for an account you hold in the United States, you may leave this field blank. Consult with the person requesting this form if you are uncertain if the financial institution is subject to these requirements. A requester may indicate that a code is not required by providing you with a Form W-9 with "Not Applicable" (or any similar indication) entered on the line for a FATCA exemption code.

A—An organization exempt from tax under section 501(a) or any individual retirement plan as defined in section 7701(a)(37).

B—The United States or any of its agencies or instrumentalities.

C—A state, the District of Columbia, a U.S. commonwealth or territory, or any of their political subdivisions or instrumentalities.

D—A corporation the stock of which is regularly traded on one or more established securities markets, as described in Regulations section 1.1472-1(c)(1)(i).

E—A corporation that is a member of the same expanded affiliated group as a corporation described in Regulations section 1.1472-1(c)(1)(i).

F—A dealer in securities, commodities, or derivative financial instruments (including notional principal contracts, futures, forwards, and options) that is registered as such under the laws of the United States or any state.

G—A real estate investment trust.

H—A regulated investment company as defined in section 851 or an entity registered at all times during the tax year under the Investment Company Act of 1940.

I—A common trust fund as defined in section 584(a).

J—A bank as defined in section 581.

K—A broker.

L—A trust exempt from tax under section 664 or described in section 4947(a)(1).

M—A tax-exempt trust under a section 403(b) plan or section 457(g) plan.

**Note:** You may wish to consult with the financial institution requesting this form to determine whether the FATCA code and/or exempt payee code should be completed.

**Line 5**

Enter your address (number, street, and apartment or suite number). This is where the requester of this Form W-9 will mail your information returns. If this address differs from the one the requester already has on file, enter "NEW" at the top. If a new address is provided, there is still a chance the old address will be used until the payor changes your address in their records.

**Line 6**

Enter your city, state, and ZIP code.

**Part I. Taxpayer Identification Number (TIN)**

**Enter your TIN in the appropriate box.** If you are a resident alien and you do not have, and are not eligible to get, an SSN, your TIN is your IRS ITIN. Enter it in the entry space for the Social security number. If you do not have an ITIN, see *How to get a TIN* below.

If you are a sole proprietor and you have an EIN, you may enter either your SSN or EIN.

If you are a single-member LLC that is disregarded as an entity separate from its owner, enter the owner's SSN (or EIN, if the owner has one). If the LLC is classified as a corporation or partnership, enter the entity's EIN.

**Note:** See *What Name and Number To Give the Requester*, later, for further clarification of name and TIN combinations.

**How to get a TIN.** If you do not have a TIN, apply for one immediately. To apply for an SSN, get Form SS-5, Application for a Social Security Card, from your local SSA office or get this form online at [www.SSA.gov](http://www.SSA.gov). You may also get this form by calling 800-772-1213. Use Form W-7, Application for IRS Individual Taxpayer Identification Number, to apply for an ITIN, or Form SS-4, Application for Employer Identification Number, to apply for an EIN. You can apply for an EIN online by accessing the IRS website at [www.irs.gov/EIN](http://www.irs.gov/EIN). Go to [www.irs.gov/Forms](http://www.irs.gov/Forms) to view, download, or print Form W-7 and/or Form SS-4. Or, you can go to [www.irs.gov/OrderForms](http://www.irs.gov/OrderForms) to place an order and have Form W-7 and/or Form SS-4 mailed to you within 15 business days.

If you are asked to complete Form W-9 but do not have a TIN, apply for a TIN and enter "Applied For" in the space for the TIN, sign and date the form, and give it to the requester. For interest and dividend payments, and certain payments made with respect to readily tradable instruments, you will generally have 60 days to get a TIN and give it to the requester before you are subject to backup withholding on payments. The 60-day rule does not apply to other types of payments. You will be subject to backup withholding on all such payments until you provide your TIN to the requester.

**Note:** Entering "Applied For" means that you have already applied for a TIN or that you intend to apply for one soon. See also *Establishing U.S. status for purposes of chapter 3 and chapter 4 withholding*, earlier, for when you may instead be subject to withholding under chapter 3 or 4 of the Code.

**Caution:** A disregarded U.S. entity that has a foreign owner must use the appropriate Form W-8.

## Part II. Certification

To establish to the withholding agent that you are a U.S. person, or resident alien, sign Form W-9. You may be requested to sign by the withholding agent even if item 1, 4, or 5 below indicates otherwise.

For a joint account, only the person whose TIN is shown in Part I should sign (when required). In the case of a disregarded entity, the person identified on line 1 must sign. Exempt payees, see *Exempt payee code*, earlier.

**Signature requirements.** Complete the certification as indicated in items 1 through 5 below.

**1. Interest, dividend, and barter exchange accounts opened before 1984 and broker accounts considered active during 1983.** You must give your correct TIN, but you do not have to sign the certification.

**2. Interest, dividend, broker, and barter exchange accounts opened after 1983 and broker accounts considered inactive during 1983.** You must sign the certification or backup withholding will apply. If you are subject to backup withholding and you are merely providing your correct TIN to the requester, you must cross out item 2 in the certification before signing the form.

**3. Real estate transactions.** You must sign the certification. You may cross out item 2 of the certification.

**4. Other payments.** You must give your correct TIN, but you do not have to sign the certification unless you have been notified that you have previously given an incorrect TIN. "Other payments" include payments made in the course of the requester's trade or business for rents, royalties, goods (other than bills for merchandise), medical and health care services (including payments to corporations), payments to a nonemployee for services, payments made in settlement of payment card and third-party network transactions, payments to certain fishing boat crew members and fishermen, and gross proceeds paid to attorneys (including payments to corporations).

**5. Mortgage interest paid by you, acquisition or abandonment of secured property, cancellation of debt, qualified tuition program payments (under section 529), ABLE accounts (under section 529A), IRA, Coverdell ESA, Archer MSA or HSA contributions or distributions, and pension distributions.** You must give your correct TIN, but you do not have to sign the certification.

## What Name and Number To Give the Requester

For this type of account:	Give name and SSN of:
1. Individual	The individual
2. Two or more individuals (joint account) other than an account maintained by an FFI	The actual owner of the account or, if combined funds, the first individual on the account <sup>1</sup>
3. Two or more U.S. persons (joint account maintained by an FFI)	Each holder of the account
4. Custodial account of a minor (Uniform Gift to Minors Act)	The minor <sup>2</sup>
5. a. The usual revocable savings trust (grantor is also trustee)	The grantor-trustee <sup>3</sup>
b. So-called trust account that is not a legal or valid trust under state law	The actual owner <sup>1</sup>
6. Sole proprietorship or disregarded entity owned by an individual	The owner <sup>3</sup>
7. Grantor trust filing under Optional Filing Method 1 (see Regulations section 1.671-4(b)(2)(i)(A)) <sup>**</sup>	The grantor <sup>4</sup>

For this type of account:	Give name and EIN of:
8. Disregarded entity not owned by an individual	The owner
9. A valid trust, estate, or pension trust	Legal entity <sup>4</sup>
10. Corporation or LLC electing corporate status on Form 8832 or Form 2553	The corporation
11. Association, club, religious, charitable, educational, or other tax-exempt organization	The organization
12. Partnership or multi-member LLC	The partnership
13. A broker or registered nominee	The broker or nominee
14. Account with the Department of Agriculture in the name of a public entity (such as a state or local government, school district, or prison) that receives agricultural program payments	The public entity
15. Grantor trust filing Form 1041 or under the Optional Filing Method 2, requiring Form 1099 (see Regulations section 1.671-4(b)(2)(i)(B)) <sup>**</sup>	The trust

<sup>1</sup>List first and circle the name of the person whose number you furnish. If only one person on a joint account has an SSN, that person's number must be furnished.

<sup>2</sup>Circle the minor's name and furnish the minor's SSN.

<sup>3</sup>You must show your individual name on line 1, and enter your business or DBA name, if any, on line 2. You may use either your SSN or EIN (if you have one), but the IRS encourages you to use your SSN.

<sup>4</sup>List first and circle the name of the trust, estate, or pension trust. (Do not furnish the TIN of the personal representative or trustee unless the legal entity itself is not designated in the account title.)

<sup>\*</sup>Note: The grantor must also provide a Form W-9 to the trustee of the trust.

<sup>\*\*</sup>For more information on optional filing methods for grantor trusts, see the Instructions for Form 1041.

Note: If no name is circled when more than one name is listed, the number will be considered to be that of the first name listed.

## Secure Your Tax Records From Identity Theft

Identity theft occurs when someone uses your personal information, such as your name, SSN, or other identifying information, without your permission to commit fraud or other crimes. An identity thief may use your SSN to get a job or may file a tax return using your SSN to receive a refund.

To reduce your risk:

- Protect your SSN,
- Ensure your employer is protecting your SSN, and
- Be careful when choosing a tax return preparer.

If your tax records are affected by identity theft and you receive a notice from the IRS, respond right away to the name and phone number printed on the IRS notice or letter.

If your tax records are not currently affected by identity theft but you think you are at risk due to a lost or stolen purse or wallet, questionable credit card activity, or a questionable credit report, contact the IRS Identity Theft Hotline at 800-908-4490 or submit Form 14039.

For more information, see Pub. 5027, Identity Theft Information for Taxpayers.

Victims of identity theft who are experiencing economic harm or a systemic problem, or are seeking help in resolving tax problems that have not been resolved through normal channels, may be eligible for Taxpayer Advocate Service (TAS) assistance. You can reach TAS by calling the TAS toll-free case intake line at 877-777-4778 or TTY/TDD 800-829-4059.

**Protect yourself from suspicious emails or phishing schemes.**

Phishing is the creation and use of email and websites designed to mimic legitimate business emails and websites. The most common act is sending an email to a user falsely claiming to be an established legitimate enterprise in an attempt to scam the user into surrendering private information that will be used for identity theft.

The IRS does not initiate contacts with taxpayers via emails. Also, the IRS does not request personal detailed information through email or ask taxpayers for the PIN numbers, passwords, or similar secret access information for their credit card, bank, or other financial accounts.

If you receive an unsolicited email claiming to be from the IRS, forward this message to [phishing@irs.gov](mailto:phishing@irs.gov). You may also report misuse of the IRS name, logo, or other IRS property to the Treasury Inspector General for Tax Administration (TIGTA) at 800-366-4484. You can forward suspicious emails to the Federal Trade Commission at [spam@uce.gov](mailto:spam@uce.gov) or report them at [www.ftc.gov/complaint](http://www.ftc.gov/complaint). You can contact the FTC at [www.ftc.gov/idtheft](http://www.ftc.gov/idtheft) or 877-IDTHEFT (877-438-4338). If you have been the victim of identity theft, see [www.IdentityTheft.gov](http://www.IdentityTheft.gov) and Pub. 5027.

Go to [www.irs.gov/IdentityTheft](http://www.irs.gov/IdentityTheft) to learn more about identity theft and how to reduce your risk.

## Privacy Act Notice

Section 6109 of the Internal Revenue Code requires you to provide your correct TIN to persons (including federal agencies) who are required to file information returns with the IRS to report interest, dividends, or certain other income paid to you; mortgage interest you paid; the acquisition or abandonment of secured property; the cancellation of debt; or contributions you made to an IRA, Archer MSA, or HSA. The person collecting this form uses the information on the form to file information returns with the IRS, reporting the above information. Routine uses of this information include giving it to the Department of Justice for civil and criminal litigation and to cities, states, the District of Columbia, and U.S. commonwealths and territories for use in administering their laws. The information may also be disclosed to other countries under a treaty, to federal and state agencies to enforce civil and criminal laws, or to federal law enforcement and intelligence agencies to combat terrorism. You must provide your TIN whether or not you are required to file a tax return. Under section 3406, payors must generally withhold a percentage of taxable interest, dividends, and certain other payments to a payee who does not give a TIN to the payor. Certain penalties may also apply for providing false or fraudulent information.



## VENDOR INFORMATION FORM

Please fill in:

Business Name \_\_\_\_\_

IRS Reporting Name \_\_\_\_\_

Business Address \_\_\_\_\_

City \_\_\_\_\_ State \_\_\_\_\_ Zip \_\_\_\_\_

Telephone ( ) \_\_\_\_\_ Extension \_\_\_\_\_

Toll Free Number 800 \_\_\_\_\_

Vendor Fax Number \_\_\_\_\_

Vendor Email Address \_\_\_\_\_

Ordering Address \_\_\_\_\_

City \_\_\_\_\_ State \_\_\_\_\_ Zip \_\_\_\_\_

Telephone ( ) \_\_\_\_\_ Extension \_\_\_\_\_

Remit Address \_\_\_\_\_

City \_\_\_\_\_ State \_\_\_\_\_ Zip \_\_\_\_\_

Telephone ( ) \_\_\_\_\_ Extension \_\_\_\_\_

Contact Person: (Ordering) \_\_\_\_\_

Remit \_\_\_\_\_

**PLEASE INCLUDE THE ABOVE INFORMATION**  
**WHEN SUBMITTING YOUR BID OR PROPOSAL**

NOTE: Section 181.23 and Section 185.04 of The Codified Ordinances of Cleveland, Ohio 1976 require that this affidavit, properly executed and containing all required information, accompany your bid. IF YOU FAIL TO COMPLY, YOUR BID WILL NOT BE CONSIDERED.

STATE OF \_\_\_\_\_ }  
COUNTY OF \_\_\_\_\_ } SS AFFIDAVIT

\_\_\_\_\_ being first duly sworn deposes and says:

**Individual only:** That he/she is an individual doing business under the name of \_\_\_\_\_, at \_\_\_\_\_, State of \_\_\_\_\_.

**Partnership only:** That he/she is the duly authorized representative of a partnership doing business under the name of \_\_\_\_\_, in the City of \_\_\_\_\_, State of \_\_\_\_\_.

**Corporation only:** That he/she is the duly authorized, qualified and acting \_\_\_\_\_ of \_\_\_\_\_, a corporation organized and existing under the laws of the State of \_\_\_\_\_.  
And that he/she said partnership or said corporation is filling herewith a bid to the City of Cleveland in conformity with the foregoing specifications;

**Individual only:** Affiant further says that the following is a complete and accurate list of the names and addresses of all persons interested in said proposed contract \_\_\_\_\_  
\_\_\_\_\_  
Affiant further says that he/she is represented by the following attorneys: \_\_\_\_\_  
and is also represented by the following resident agents in the City of Cleveland: \_\_\_\_\_  
\_\_\_\_\_

**Partnership only:** Affiant further says that the following is a complete and accurate list of the names and addresses of the members of said partnership: \_\_\_\_\_  
\_\_\_\_\_  
Affiant further says that said partnership is represented by the following attorneys: \_\_\_\_\_  
and is also represent by the following resident agents in the City of Cleveland: \_\_\_\_\_  
\_\_\_\_\_

**Corporation only:** Affiant further says that the following is a complete and accurate list of the officers, directors and attorneys of said corporation:  
 President: \_\_\_\_\_ Directors: \_\_\_\_\_  
 Vice President: \_\_\_\_\_  
 Secretary: \_\_\_\_\_  
 Treasurer: \_\_\_\_\_  
 Cleveland Manager or Agent \_\_\_\_\_  
 Attorneys: \_\_\_\_\_  
 And that the following officers are duly authorized to execute contracts on behalf of said corporation:

\_\_\_\_\_  
 \_\_\_\_\_  
 \_\_\_\_\_

Affiant further says that the bid filed herewith is not made in the interest of or on behalf of any undisclosed person, partnership, company, association, organization or corporation; that such bid is genuine and not collusive or sham; that said bidder has not, directly or indirectly, induced or solicited any other bidder to put in a false or sham bid, and has not, directly or indirectly, colluded, conspired, connived or agreed with any bidder or anyone else to put in a sham bid, or that anyone shall refrain from bidding; that said bidder has not in any manner, directly or indirectly, sought by agreement, communication or conference with anyone to fix the bid price or that of any other bidder, or to secure any advantage against the City of Cleveland or anyone interested in the proposed contract; that all statements contained in such bid are true; that said bidder has not, directly or indirectly, submitted his bid price or any break-down thereof or the contents thereof, or divulged information or data relative thereto, or paid or agreed to pay, directly or indirectly, any money, or other valuable consideration for assistance or aid rendered or to be rendered in procuring or attempting to procure the contract above referred to, to any corporation, partnership, company, association, organization, or to any member or agent thereof, or to any other individual, except to such person or persons as hereinabove disclosed to have a partnership or other financial interest with said bidder in his general business; and further that said bidder will not pay or agree to pay, directly or indirectly, any money or other valuable consideration to any corporation, partnership, company, association, organization or to any member or agent thereof, or to any other individual, for aid or assistance in securing contract above referred to in the event the same is awarded to

\_\_\_\_\_  
 (name of individual, partnership or corporation)

Further affiant saith not.

(Sign Here)  \_\_\_\_\_

Sworn to before me and subscribed in my presence this \_\_\_\_\_ day of \_\_\_\_\_, 20\_\_\_\_.

\_\_\_\_\_  
 Notary Public

CITY OF CLEVELAND

**BID BOND**

KNOW ALL MEN BY THESE PRESENTS, That we

\_\_\_\_\_

as Principal, and

\_\_\_\_\_

a corporation duly authorized to do business in Ohio, as Surety, are held and firmly bound unto

THE CITY OF CLEVELAND

as Obligee, in the penal sum of \_\_\_\_\_

Dollars, lawful money of the United States of America, for the payment of which, well and truly to be made, we bind ourselves, our heirs, executors, administrators, successors and assigns, jointly and severally, firmly by these presents.

SIGNED, sealed and dated this \_\_\_\_\_ day of \_\_\_\_\_, 20 \_\_\_\_\_.

WHEREAS, the said principal is herewith submitting bid for

\_\_\_\_\_  
\_\_\_\_\_  
\_\_\_\_\_

Now, THEREFORE, the condition of the above obligation is such that if the said principal shall execute a contract and give bond for the faithful performance within ten (10) working days after being notified in writing of the award of such contract to the principal, or if the principal or surety shall pay the obligee the sum, not exceeding the penalty hereof, by which the amount of the contract, covering the said proposal, properly and lawfully executed by and between the obligee and some third party, may exceed the amount bid by principal, then this obligation shall be void; otherwise it shall remain in full force and effect.

PRINCIPAL \_\_\_\_\_

BY: \_\_\_\_\_

TITLE \_\_\_\_\_

By \_\_\_\_\_  
Attorney in Fact

CITY OF CLEVELAND

**BID FORM**

STANDARD CONTRACT BID  
 REQUIREMENT CONTRACT BID

TO: The Commissioner of Purchases and Supplies:

BID FOR Valves and Appurtenances 20-inch and Larger Re-Bid

FOR: The Department of: Public Utilities, Division of Water

The Undersigned proposes to furnish the above articles, commodities, materials, supplies, equipment or services ("items"), and to accept as full compensation therefor the price per unit multiplied by the number of units of such items purchased hereunder, (which units and prices therefor are set forth in the Schedule of Items hereto attached and made part of this bid) and subject to any discount set forth in this bid.

The Undersigned further proposes to execute the Contract Agreement and to furnish satisfactory performance bond within ten (10) working days, excluding Saturdays, Sundays and holidays, after notice of award of contract has been received.

The Undersigned further certifies that he (as the individual, firm or corporation making this bid) is not in arrears or default to the City of Cleveland upon any debt or contract, nor is a defaulter as surety or otherwise upon any obligation to said City, nor has failed to perform faithfully any previous contract with said City and that there is no suit or claim pending as to any such arrears or default.

The Undersigned deposits with the bid a Bid Bond to the City of Cleveland signed by a surety company authorized to do business in Ohio, in the sum of \$ \_\_\_\_\_

or a cashier's check or certified check on a solvent bank in the sum of \$ \_\_\_\_\_ payable to the City of Cleveland, as security that if he be awarded the contract, he will enter into a written contract and secure the performance of the same by a bond as required of an approved surety company authorized to do business in Ohio and satisfactory to the Director of Law, in the sum equal to the percentage of the total price bid set forth in Part B – General Conditions and in conformity with the provisions of The Codified Ordinances of Cleveland, Ohio 1976.

The Undersigned further agrees that if the bid is accepted and contract awarded and he shall fail to execute said contract and furnish the satisfactory bond, as required, within the time above specified, then the City may, at its option, declare the contract abandoned and this bid null and void. Thereupon the penal sum of the Bid Bond shall become due to the City, or the certified or cashier's check shall be forfeited to and become the property of the City as liquidated damages. Otherwise, the Bid Bond or the certified or cashier's check, or the amount of such check shall be returned to the Undersigned.

THE UNDERSIGNED UNDERSTANDS THAT THE CITY RESERVES THE RIGHT TO REJECT ANY OR ALL BIDS.

The firm, corporation, or individual name  
MUST BE SIGNED IN SPACE INDICATED.  
ERASURES MAY INVALIDATE THIS BID.

Complete: *CORPORATION OR FIRM*

Sign Here By \_\_\_\_\_

If the bidder is a firm or corporation, the title  
of the officer signing and the State in which  
Incorporated must be indicated.

\_\_\_\_\_  
TITLE OF OFFICER

\_\_\_\_\_  
BUSINESS ADDRESS OF BIDDER

\_\_\_\_\_  
STATE OF INCORPORATION



**BID - SCHEDULE OF ITEMS**  
**City of Cleveland**  
**Division of Purchases And Supplies**  
**601 Lakeside Avenue, Room 128**  
**Cleveland, Ohio 44114**

BID PAGE 2 of 3

BIDDER MUST  
SIGN AND DATE THIS SHEET

AUTHORIZED SIGNATURE

TITLE OF BID

**VALVES AND APPURTENANCES 20-INCH AND LARGER RE-BID**

DATE

DESCRIPTION	QUANTITY	UNIT PRICE	EXTENSION
<b>VALVES 20-INCH AND LARGER - AWWA C509</b>			
8. 20" Square Head Gate Valves, MJ Ends, as specified w/ accessories. Manufacturer: _____ Model#: _____ Average Weight: _____ Lbs.	Price 2 EA	\$	\$
9. 24" Square Head Gate Valves, MJ Ends, as specified w/ accessories. Manufacturer: _____ Model#: _____ Average Weight: _____ Lbs.	Price 2 EA	\$	\$
10. 30" Square Head Gate Valves, MJ Ends, as specified w/ accessories. Manufacturer: _____ Model#: _____ Average Weight: _____ Lbs.	Price 1 EA	\$	\$
11. 36" Square Head Gate Valves, MJ Ends, as specified w/ accessories. Manufacturer: _____ Model#: _____ Average Weight: _____ Lbs.	Price 1 EA	\$	\$
12. 42" Square Head Gate Valves, MJ Ends, as specified w/ accessories. Manufacturer: _____ Model#: _____ Average Weight: _____ Lbs.	Price 1 EA	\$	\$
13. 48" Square Head Gate Valves, MJ Ends, as specified w/ accessories. Manufacturer: _____ Model#: _____ Average Weight: _____ Lbs.	Price 1 EA	\$	\$
14. 54" Square Head Gate Valves, MJ Ends, as specified w/ accessories. Manufacturer: _____ Model#: _____ Average Weight: _____ Lbs.	Price 1 EA	\$	\$
<b>VALVES 20-INCH AND LARGER - AWWA C515</b>			
15. 20" Square Head Gate Valves, MJ Ends, as specified w/ accessories. Manufacturer: _____ Model#: _____ Average Weight: _____ Lbs.	Price 2 EA	\$	\$
ALL QUANTITIES ARE APPROXIMATE AMOUNTS. THE CONTRACT, IF ANY, SHALL BE FOR A PERIOD OF ONE (1) YEAR.		DELIVERY (Days)	PAYMENT DISCOUNT
BIDDER MUST SIGN AND DATE THIS SHEET			% Days
FOR PURCHASING USE ONLY			

**BID - SCHEDULE OF ITEMS**  
**City of Cleveland**  
**Division of Purchases And Supplies**  
**601 Lakeside Avenue, Room 128**  
**Cleveland, Ohio 44114**

BID PAGE 3 of 3

BIDDER MUST  
SIGN AND DATE THIS SHEET

AUTHORIZED SIGNATURE

TITLE OF BID

**VALVES AND APPURTENANCES 20-INCH AND LARGER RE-BID**

DATE

DESCRIPTION	QUANTITY	UNIT PRICE	EXTENSION
16. 24" Square Head Gate Valves, MJ Ends, as specified w/ accessories. Manufacturer: _____ Model#: _____ Average Weight: _____ Lbs.	Price 2 EA	\$	\$
17. 30" Square Head Gate Valves, MJ Ends, as specified w/ accessories. Manufacturer: _____ Model#: _____ Average Weight: _____ Lbs.	Price 2 EA	\$	\$
18. 36" Square Head Gate Valves, MJ Ends, as specified w/ accessories. Manufacturer: _____ Model#: _____ Average Weight: _____ Lbs.	Price 1 EA	\$	\$
19. 42" Square Head Gate Valves, MJ Ends, as specified w/ accessories. Manufacturer: _____ Model#: _____ Average Weight: _____ Lbs.	Price 1 EA	\$	\$
20. 48" Square Head Gate Valves, MJ Ends, as specified w/ accessories. Manufacturer: _____ Model#: _____ Average Weight: _____ Lbs.	Price 1 EA	\$	\$
21. 54" Square Head Gate Valves, MJ Ends, as specified w/ accessories. Manufacturer: _____ Model#: _____ Average Weight: _____ Lbs.	Price 1 EA	\$	\$
22. Special parts or special size valves & appurtenances in the estimated amount of ten thousand dollars (\$10,000.00). Section C-6	\$ 10,000.00 (Allowance)		\$
		(% Mark-up)	(Extension)

ALL QUANTITIES ARE APPROXIMATE AMOUNTS. THE CONTRACT, IF ANY, SHALL BE FOR A PERIOD OF ONE (1) YEAR.

BIDDER MUST SIGN AND DATE THIS SHEET

DELIVERY  
(Days)

PAYMENT DISCOUNT

% Days

FOR PURCHASING USE ONLY

## GENERAL CONDITIONS

- B-1 CONSIDERATION OF BIDS.**  
All bids received in conformity with the invitation to Bid shall be endorsed with the contract or advertisement name or number and name and address of the bidder. All bids, immediately after being read, shall be tabulated and summarized and shall become public record in the office of the Commissioner of Purchases and Supplies.
- B-2 UNACCEPTABLE BIDS.**  
No bid will be accepted from, nor a contract awarded to, any person, firm or corporation that is in arrears or is in default to the City upon any debt or contract, or is a defaulter as surety or otherwise upon any obligation to the City, or has failed to perform faithfully on any previous contract with the City of Cleveland.
- B-3 REJECTION OR ACCEPTANCE OF BIDS.**  
The City through the Board of Control shall have the right to reject any or all bids, parts of such bid, and reserves the right to waive any informalities in the bid. In addition to bid price and discount, the City reserves the right to consider all elements entering into the question of determining the responsibility of the bidder. Any bid which is incomplete, conditional, obscure, contains additions not called for, or irregularities of any kind, may be cause for rejection of the bid.
- B-4 EVIDENCE OF ABILITY TO FULFILL CONTRACT.**  
Bidders must present evidence to the Commissioner of Purchases and Supplies, when required by him to do so, to show they are fully competent and have the necessary source of supply, facilities and pecuniary resources to fulfill the conditions of the contract and specifications.
- B-5 WITHDRAWAL OF BID.**  
No bid may be withdrawn after it has been deposited with the Commissioner of Purchases and Supplies.
- B-6 TIME OF AWARD.**  
The Board of Control of the City of Cleveland shall make an award or reject all bids not later than the second regular meeting of said Board following the opening of bids, unless further time is required to analyze bids, to investigate responsibility of any bidder, or in the absence of a time limitation for acceptance set forth in the bid.  
Any extension of time beyond the date fixed by the successful bidder or the fourth regular meeting of the Board of Control, whichever event shall occur first, shall be subject to agreement between said bidder and the Board.
- B-7 AWARD CONTRACT.**  
No contract shall be awarded without the approval of the Board of Control, and then only to the lowest and best bidder.

**B-8 PERFORMANCE BOND.**

A. Contracts for the purchase of articles, supplies, commodities, materials, equipment or services shall be secured by a bond in the form and content prescribed by and acceptable to the Director of Law, with good and sufficient sureties and in an amount equal to at least twenty-five percent (25%) of the contract price on materials supplied and at least fifty percent (50%) of the contract price on services supplied. A check is not acceptable in place of a performance bond. A performance bond is not required for standard purchase and requirements contracts awarded in the amount of \$500,000.00 or less, except that standard purchase and requirements contracts that are labor and materials contracts including, but not limited to painting, carpentry, plumbing, electrical, masonry, landscaping, snow plowing, fencing and trucking over \$100,000 but not more than \$250,000 shall require a bond of at least twenty-five percent of the contract price, and over \$250,000 but not more than \$500,000 shall require a bond of at least fifty percent of the contract price. The above policy notwithstanding, the City of Cleveland reserves the right to require a performance bond in various amounts or to modify the performance bond requirement whenever it is determined to be in the best interest of the City of Cleveland to do so.

B. No performance bond will be required on any contract in the amount of \$500,000.00 or less issued pursuant to this Invitation to Bid (ITB). Any contract over \$500,000.00 shall require a bond of twenty-five percent (25%).

**B-9 RELEASE OF BOND.**

Whenever a performance bond is required, the performance bond will not be released until all the provisions of the contract have been fulfilled.

**B-10 CANCELLATION OF CONTRACT.**

The City shall have the right to cancel this contract on five (5) days written notice if, in the opinion the Commissioner of Purchases and Supplies, the delivery of materials, supplies or equipment or the performance of work or services are not in accordance with contract specifications and the contractor fails to cure such deficiencies or comply with the contract specifications within ten (10) days after receipt of notice of default from the City, except where fulfillment of its obligation requires activity over a period of time and it has, within ten (10) days of the default notice commenced such activity. Additionally, the City shall have the right to cancel this contract, without cause, upon fifteen (15) days written notice upon the determination of the Board of Control of the City, expressed through its resolution, to do so.

**B-11 SUBCONTRACTING OR ASSIGNMENT OF CONTRACT.**

a. The contractor shall not subcontract, sublet, assign, transfer, convey or otherwise dispose of the contract, its duties, rights, title or interest in it or in any part thereof, or assign, by power of attorney or otherwise, any of the monies due or to become due under the contract, except, in each instance, with the prior written authorization of the Board of Control of the City, expressed through its resolution, and then only upon such terms and conditions as may be agreed to by said Board. No such subcontracting, subletting, assignment, transfer, conveyance or other disposal of the contract shall be valid until filed in the office of the Commissioner of Accounts.

b. Prior written Board of Control consent is required for a City contractor to add a subcontractor, or to substitute one subcontractor for another subcontractor, under a City contract.

c. The City assumes no obligation to pay, and will not pay, a contractor for any work and or services performed by a sub-contractor on the contract prior to Board of Control approval of that sub-contractor.

d. The Director will not grant any City contractor additional time to meet project deadlines, and will not authorize or pay additional compensation or delay damages of any kind arising from the contractor's inability to add or substitute a subcontractor because the contractor failed to submit the approval request and supporting documentation at least 3 (three) weeks in advance of the date the additional or substitute sub-contractor is needed.

e. The Office of Equal Opportunity shall evaluate each subcontractor addition and substitution for increased CSB, MBE, or FBE participation even if the original contract had no certified sub-contractor participation.

f. The City's Sub-contractor Addition and Substitution Policy and Procedure is hereby incorporated by reference in its entirety. The complete document is available online at the City of Cleveland website: <http://www.city.cleveland.oh.us>.

**B-12 DELAY FOR CAUSES BEYOND CONTROL.**

If the contractor is delayed in complying with the terms of the contract by strikes, lockouts, fire, unusual delay by common carriers, unavoidable casualties, or any cause beyond the contractor's control including orders, limitations or restrictions of any Governmental agency having jurisdiction over the subject matter of the contract, or by delay authorized by the City, or for any cause by which the director shall decide to justify the delay; then for all such delays and suspensions, the contractor shall be allowed one calendar day extension beyond the time fixed for compliance with the terms of the contract for each and every calendar day of such delay so caused in the completion of the work, the same to be ascertained by the director.

**B-13 PATENTS.**

The Contractor shall be required to pay all royalties and license fees and shall hold and save the City and its officers, agents, servants and employees harmless from liability of any nature or kind, including cost and expenses, for or on account of any patented or unpatented invention, process, article, or appliance manufactured or used in the performance of the contract, including its use by the City of Cleveland unless otherwise specifically stipulated in the contract documents. In this respect the contractor shall defend all suits or claims for infringement of any patent or license rights.

**B-14 DELIVERY.**

The vendor shall adhere to all stipulated delivery terms (e.g., material / service delivery upon a pre-set schedule, upon orders being placed, etc.). All service performance / material deliveries should be made only if the City of Cleveland has issued a valid, open Purchase Order (PO) with a sufficient free balance to

cover the full costs of the service being performed or materials being delivered. The City will not pay vendors for goods or services that are either delivered to the City under an invalid or unauthorized PO or were ordered using an expired contract. The City is not responsible for, and will not pay for, goods or services delivered to the City that are not authorized under the PO and contract under which a sale was purportedly made. Therefore, the vendor must not perform any services nor deliver any materials without a valid, open PO that authorizes the services / materials and that carries a sufficient free balance to cover the services / materials.

Upon delivery, some form of delivery documentation must be left with the City of Cleveland Department. For service performed, some Proof of Service documentation must be given to a City employee. For materials delivered, some Proof of Delivery or Packing Slip must be given to a City employee. In all instances, the delivery documentation must be signed and dated by a City employee in order to substantiate the services provided or materials delivered were as indicated on the documentation. City employees are charged with performing this verification, so vendors should allow adequate time for this review to occur. Failure to provide some delivery documentation, which received a City signature and date upon delivery, may result in payment delays.

**B-15 LABORATORY TEST.**

The City of Cleveland reserves the right to test all materials, equipment or supplies delivered during the life of the contract, at an independent laboratory to be designated by the Commissioner of Purchases and Supplies of the City of Cleveland. Where the result of such test shows the materials, equipment or supplies are not equal to the specifications, then the expense of making such test shall be paid by the contractor.

**B-16 FAILURE TO MEET SPECIFICATIONS.**

The delivery of any material, supplies or equipment or the performance of any work or services under the contract which do not conform to contract specifications will be rejected and the contractor notified immediately in writing of such rejection and the reason therefore. If the time for performance has not expired, and the contractor wishes to remedy the deficient materials, supplies or equipment or performance, it may notify the Commissioner of Purchases and Supplies of its intention to cure and may within ten (10) days make a conforming delivery of performance unless such time is extended in writing by said Commissioner. If said contractor fails to replace such nonconforming materials, supplies or equipment or otherwise cure such deficient performance of work or services, the City of Cleveland will purchase such materials, supplies or equipment or obtain the performance of such work or services of the character required on the open market or in case of work and services, by performance by City employees. In such event, the contractor and his surety shall be liable to the City for any excess costs and expenses thereby incurred.

**B-17 SAFEGUARDS.**

Any equipment to be furnished by the terms of this bid, shall be provided with safety controls, guards, and housing meeting the requirements of the safety standards of the Industrial Commission and the Department of Industrial Relations of Ohio, and the cost shall be included as part of the bid.

**B-18 STATE OR FEDERAL TAXES.**

- a. The City of Cleveland is exempt from all sales, excise and transportation taxes, except State of Ohio gasoline tax. The price or prices bid shall be exclusive of all such taxes and will be so construed.
- b. The contract price is subject to increase by the amount of any additional tax imposed by the Federal Government or the State of Ohio subsequent to the receipt of bids. Such claim for increased prices must be presented to the City within thirty (30) days after such tax becomes effective and supported by evidence satisfactory to the Director of Law.
- c. The contract price is subject to reduction by that amount by which an applicable tax is reduced during the period of the contract.

**B-19 SOCIAL SECURITIES ACT/EMPLOYEES BENEFIT PAYMENTS.**

The contractor shall be and remain an independent contractor with respect to all services performed under said contract, and agrees to and accepts full and exclusive liability for the payment of any and all contributions or taxes for social security, unemployment insurance, old age retirement benefits, pensions, or annuities now or hereafter imposed under any state or federal law, which are measured by the terms of this contract and further agrees to obey all lawful rules and regulations and to meet all lawful requirements which are now or hereafter may be issued or promulgated under said respective laws by and duly authorized state or federal officials and said contractor also agrees to indemnify and save harmless the City of Cleveland from any such contributions or taxes or liability therefore.

**B-20 FREIGHT ON DIRECT SHIPMENTS TO THE CITY.**

The freight prices made in the bid are to be in accordance with lawful freight or cartage charges in existence at the time the bid is made, and contract prices shall be increased or decreased by changes in the freight or cartage rates, provided that claims for additional freight or cartage be presented to the City of Cleveland within thirty (30) days after said advance in freight or cartage rates becomes effective. Reductions in freight or cartage prices will be deducted from the contract price.

**B-21 INVOICING AND PAYMENT.**

The Contractor shall submit invoices that appropriately reflect the work performed. Original invoices must be typed and legible. The City of Cleveland does not pay from duplicates or copies. Each invoice must be mailed as specified below:

- Original invoice to address as shown on Purchase Order under "BILL TO:"
- Optional: Copy of invoice to the City of Cleveland, Division of Accounts, 601 Lakeside Avenue, Cleveland, OH 44114, clearly marked "COPY".
- Address invoice questions first to the ordering department. The Division of Accounts will assist if the Department is unable to resolve the question.

The failure to deliver copies of invoices to the indicated location may lead to delays in payment.

Invoices submitted by the Contractor for payment must include the following information:

- Contractor Name, as it appears on the Contract;
- Contractor Mailing Address;
- Contractor Telephone Number;
- Contractor Facsimile Number;
- Contract Number;
- Purchase Order (PO) Number under which the work being invoiced was authorized;
- Contractor Invoice Number, which must be a unique (non-recurring) number;
- Invoice Date, reflecting the date that the invoice itself was issued to ;
- Timeframe that the invoice covers;
- A detailed itemization of labor and materials provided, including:
  - Date that work was performed / material delivered,
  - Location for each item of service performed / material delivered,
  - Line Item Number from the Contract's Schedule of Items (SOI) that is being invoiced,
  - Quantity of items being invoiced under each Line Item,
  - Unit Cost of each Line Item,
  - Extended Cost by each Line Item.
- delivery documentation (e.g., Proof of Service / Delivery slip, Packing Slip, etc.) with an acknowledgement signature and date from a City of Cleveland employee;

The City of Cleveland is not subject to sales tax per Section 5739.01 (B)(1) O.R.C. Therefore invoices must not charge sales tax. The City's Tax Exemption Number is 34-6000646. Tax Exemption Certificates are available upon request from the Division of Purchases and Supplies.

Any applicable discounts, as stipulated through the contract and/or PO, must be itemized and applied to the invoice. Any special instructions contained within the contract must also be followed.

If any invoice is erroneous or does not include the above required information, the City shall inform the supplier as to the reasons thereof and any corrective actions necessary to qualify the invoice for payment by the City. The vendor is responsible for providing the delivery documentation at the time of delivery and for submitting the invoice.

**B-22 EQUAL OPPORTUNITY.**

This contract is a contract, and contractor is a contractor within the meaning of Chapter 187 of the Codified Ordinances of Cleveland, Ohio 1976. During the term, the contractor shall comply with all terms, conditions and requirements imposed on "contractor" in the Equal Opportunity Clause, Section 187.22(b) of

the Codified Ordinances of Cleveland, Ohio 1976, attached hereto and made a part hereof. A copy of such clause shall be made a part of every subcontract of agreement entered into for goods or services and shall be binding on all persons, firms and corporations with whom the contractor may deal.

**PARAGRAPHS B-23 AND B-24 APPLY ONLY IF THE REQUIREMENT CONTRACT BID BLOCK IS MARKED ON BID PAGE 1 OF BID AND ON BID FORM.**

**B-23 DURATION OF CONTRACT.**

The proposed contract shall be effective upon its execution and approval by the Director of Law of the City of Cleveland and, for the purpose of accepting delivery, shall continue in full force and effect for the period specified in the specifications and/or the Schedule of Items section of the bid, unless otherwise indicated.

**B-24 REDUCTION IN PRICES.**

The contractor agrees that if the price to the general trade is reduced while the contract is in effect, the City of Cleveland will receive the benefit of such reduction immediately. However, if the contract price is below the price to the general trade at the time the contract is awarded, the reduction provision will be effective only when the recognized price to the general trade reaches a level lower than the contract price or when the contractor reduces his own price to a level lower than the contract price.

**B-25 EIGHT-HOUR DAY, MINIMUM WAGE, AND NON-DISCRIMINATION.**

The Contractor agrees that it shall comply with the following provisions of the Charter of the City of Cleveland, which are, respectively, as follows:

Section 196. Except in case of extraordinary emergencies; not to exceed eight (8) hours will constitute a day's work and not to exceed forty eight (48) hours a week's work, for any City employee of the City of Cleveland in the classified service thereof, and for any workmen engaged in public work carried on or aided by the municipality whether done by contract or otherwise. The Council shall by ordinance, provide for the enforcement of the provisions of this section.

Section 197. Every contract for public work entered into by the City of Cleveland shall contain, and no contract shall be entered into unless it contains the following stipulations:

The Contractor hereby agrees that all persons employed by him will be paid wages which are not less than are paid by the City of Cleveland for similar or like work; but if said City has not established a rate of wages for any particular class of work to be performed under the terms of this contract, then said employees shall be paid wages not less than are generally paid therefore by others employing union labor in said City.

The Contractor hereby further agrees that in the employment of labor, skilled or unskilled, under the Contract there will be no discrimination exercised against any citizen because of race, color, religion or national origin; and that any violation hereof shall be deemed a material breach of said contract.

**B-26 LAWS, PERMITS, AND REGULATIONS**

The contractor shall comply with all applicable laws of the Federal government, State, ordinances of the City or other municipality in which the work or services are being done and all applicable regulations and any authorized regulations, and shall be responsible for securing at his own expense any and all licenses, permits and certificates of inspection required by law or by the contract documents.

**SERVICES, LABOR & MATERIALS - IF THIS CONTRACT IS FOR WORK, SERVICES, OR LABOR & MATERIALS, B-27, 28 AND B-29 APPLY**

**B-27 STATE INDUSTRIAL COMPENSATION FOR PURCHASE OF LABOR AND MATERIALS.**

If this contract contains labor, whether in part or in all, the contractor shall, in all cases during the term of this contract, subscribe to and comply with the Worker's Compensation Laws of the State of Ohio and pay such premiums as may be required thereunder and to save said City harmless from any and all liability arising from said act. He shall also furnish at the time of delivery of this contract and such other times as may be requested, a copy of the official certificate or receipt showing the payments hereinbefore referred to. A copy of the official certificate or receipt showing the payments hereinbefore referred to, shall be submitted with the bid, or, if not included with the bid, shall be submitted with the signed contract. No work shall be commenced, or payments made, until the certificate or receipt is received by the City. The contractor shall maintain continuous coverage throughout the contract and shall notify the City in writing within 24 hours of receipt of notice of cancellation or reduction of coverage.

**B-28 INDEMNITY**

Contractor shall indemnify, defend, and hold harmless the City of Cleveland, Ohio, its officers, agents, and employees from all claims, demands, liabilities, loss, suits, causes of action, judgments, costs, and expenses, including attorneys' fees, arising, occurring, or allegedly arising or occurring from personal injury, including death, property damage, including loss of use, or otherwise, to any person or the property of any person, including third parties and employees of any party, as a result of negligent or intentional act or omission by Contractor or its agents, employees, subcontractors or suppliers, in performing work or services or furnishing labor and materials under this contract. This indemnification right is in addition to any other indemnification or contribution right of any indemnified party and shall survive completion of the work or services or furnishing of labor and materials.

**B-29 WARRANTY**

Contractor warrants, in addition to any other express or implied warranty required by law or the contract, that all work and services performed under this Agreement will be of good quality, free from faults and defects, conform to the contract documents, performed in a workmanlike manner according to good usage and

accepted practice, resulting in a merchantable product, and fit and suitable for their intended purpose, and that materials supplied will be of good quality and free from all defects, latent or patent.

#### **B-30 OHIO CAMPAIGN FINANCE LAW**

Pursuant to the Ohio Revised Code, as referenced below, the following language is hereby made a part of this document:

"Contractor hereby certifies that beginning on the date the contract is awarded and extending until one year following conclusion of the contract, all persons identified in Ohio Revised Code Sections 3517.13(I)(3) and 3517.13(J)(3), as applicable, are in compliance with Ohio Revised Code Sections 3517.13(I)(1) and 3517.13(J)(1)."

By submitting a signed sealed bid, those persons signing the document are affirming their compliance with the referenced sections of the Ohio Revised Code, herein incorporated into any contract created pursuant to this Invitation to Bid in its entirety.

#### **B-31 TITLE 48 C.F.R. ETC:**

Certification Re: Federal Debarment, Suspension, Ineligibility or Voluntary Exclusion; Title 48 Code of Federal Regulations, Part 9, and other regulations, preclude the City from participating in a covered transaction, as defined in subpart 9.4, with any agency, corporation, partnership, or other legal entity that has been debarred, suspended, proposed for debarment, declared ineligible, or voluntarily excluded by the Federal Government from participating in transactions involving Federal funds. By signing and submitting this document, the bidder certifies to City that it, its principals, any subcontractors, and subcontractor principals:

- 1) Are not presently debarred, suspended, proposed for debarment, declared ineligible, or voluntarily excluded by any Federal department or agency;
- 2) Have not within the three-year period immediately preceding the submission date of this document been convicted of or had a civil judgment rendered against them personally or the company for commission of fraud or a criminal offense in connection with obtaining, attempting to obtain, or performing a public (Federal, State or Local) transaction or contract under a public transaction; violation of Federal or State antitrust statutes or commission of embezzlement, theft, forgery, bribery, falsification or destruction of records, making false statements, or receiving stolen property;
- 3) Are not presently indicted for or otherwise criminally or civilly charged by a government entity (Federal, State or local) with commission of any of the offenses enumerated in paragraph (1)(b) of this certification; or,
- 4) Have not within the three-year period immediately preceding submission date of this document had one or more public transactions (Federal, State or local) terminated for cause or default.

If the bidder is unable to certify to any of these statements in this certification, such prospective participant must attach a written explanation to this bid. Failure or inability to certify to any of these statements may be cause for rejection of the bid.

The Federal Debarred Listing is available at <http://www.epls.gov/>

By submitting a signed sealed bid, those persons signing the document are affirming their compliance with the referenced sections of the Code of Federal Regulations, herein incorporated into any contract created pursuant to this Invitation to Bid in its entirety.

**SPECIFICATIONS/DESCRIPTIONS OF PRODUCTS AND/OR SERVICES  
DEPARTMENT OF PUBLIC UTILITIES – DIVISION OF WATER**

**SECTION C – SUPPLEMENTAL GENERAL CONDITIONS  
VALVES AND APPURTENANCES 20-INCH AND LARGER RE-BID**

**C-1 SCOPE**

It is the intent of this contract to provide the Cleveland Division of Water (CWD) - Distribution and Maintenance with valves and appurtenances 20-inches and larger in the estimated quantities, as specified on the attached Bid – Schedule of Items (SOI) pages. The bidder shall furnish all materials for valves, as required, for the proper completion of the work included under this Contract. This work shall include the furnishing, testing, painting, and shipping of the various valve types, sizes, and joints as specified herein, including vertical and horizontal gate valves with bypass valves and valve boxes. All buried valves shall have CWD standard sized operating nuts and all other accessories and appurtenances including, where required, valve stem extension (in valve box) and/or valve rod extension (in valve vault) and the furnishing of all non-standard tools, accessories and appliances as specified or as shown. All items to be purchased under the terms of this requirement contract shall comply with all requirements set forth in this specification.

**C-2 CITY OF CLEVELAND FORMS**

Failure to submit the following City of Cleveland (City) forms with the Bid **will** cause your bid to be non-responsive.

A. Bid Bond

1. Use the City's Bid Bond form.
2. Follow the instructions in Part B and C of the Bidder's Check List completely.
3. A bid bond is not required if your total bid is \$50,000.00 or less.

B. Bid Form

1. Indicate whether you are submitting a bid bond or a cashier's check/certified check in the amount of 5 percent (%) of your bid total.
2. The information at the bottom of the page must be filled out completely and signed by an officer of the corporation or firm.

C. Affidavit

1. The first three lines of the affidavit must be filled out stating the state, county, and name of the person being sworn.
2. The state on page one must be the same state as the notary's commission stamp that appears at the bottom of page two.
3. The Notary must display the date their commission expires at the bottom of page two unless state requirements differ.
4. Be sure that the proper lines are used on page two for signing for the person that is being sworn.
5. Fill out all necessary information on both sides of the affidavit.

D. Wage Theft and Payroll Fraud Disclosure

1. If any adverse determinations have been made please attach.
2. Sign at the bottom of page 2.

**SPECIFICATIONS/DESCRIPTIONS OF PRODUCTS AND/OR SERVICES  
DEPARTMENT OF PUBLIC UTILITIES – DIVISION OF WATER**

**SECTION C – SUPPLEMENTAL GENERAL CONDITIONS  
VALVES AND APPURTENANCES 20-INCH AND LARGER RE-BID**

Any other forms that are included in the bid package should be filled out completely, signed where necessary and returned.

**C-3 PRE-BID MEETING/LAST DAY FOR QUESTIONS**

- A. A pre-bid meeting will be held on the date and time as per the advertisement announcement. Bidders are cautioned that questions, clarifications, and information that may result from this meeting could affect your bid. By City policy, this is the only opportunity for potential bidders to speak directly with the City personnel prior to award of the contract. Attendance at the pre-bid meeting is non-mandatory.
- B. The last day for questions is 7 business days before the bid opening date. All questions should be submitted in writing to the Division of Purchases and Supplies by email, [jgilliam@clevelandohio.gov](mailto:jgilliam@clevelandohio.gov) and [purchasing@clevelandohio.gov](mailto:purchasing@clevelandohio.gov), or fax, 216-664-2275.

**C-4 METHOD OF AWARD**

CWD will award the lowest cost and best bid for each separate bid item.

- A. Delivery time will be factored into the evaluation process to determine the lowest and best bid. List delivery time in days; **do not** list delivery as a range of days in the Bid - Schedule of Items pages. For example, if a bidder proposes a delivery range of 120 days to 300 days, the bid item(s) in question **will** be considered non-responsive.
- B. If various items have the same delivery lead times, list them together. For example, delivery times for items 1-18 and 33-38 are 120 days; delivery times for items 19-32 are 40 days.
- C. For special parts or special size valves & appurtenances (Item 22) bid evaluation purposes: Any markup from invoice cost not clearly stated, will be disregarded in determining the lowest and best bid, and the price quoted will be considered as a net price.
- D. Including exceptions or conditions in the bid is not recommended and may cause the bid to be considered non-responsive.

**C-5 MANUFACTURERS**

- A. Bidders proposing to submit items from the approved manufacturer lists need not submit drawings unless modifications have been made that differ from the pre-approved drawing on file with CWD.
- B. Bidders proposing to submit items from the approved manufacturer lists need only list the model name, from the approved list, on the Bid - Schedule of Items. If a model number on any pre-approved list has been updated, please submit a separate sheet of paper spelling out the changes that need to be made.

**SPECIFICATIONS/DESCRIPTIONS OF PRODUCTS AND/OR SERVICES  
DEPARTMENT OF PUBLIC UTILITIES – DIVISION OF WATER**

**SECTION C – SUPPLEMENTAL GENERAL CONDITIONS  
VALVES AND APPURTENANCES 20-INCH AND LARGER RE-BID**

- C. Bidders proposing to submit items not on the City's pre-approved list must submit with its bid sufficient evidence that the proposed items meet all the City's requirements as outlined in section C-6 Submittals. Said evidence shall be submitted concurrently with the bid as part of the sealed bid package.

Bidders may also submit three (3) references where the valves have been used successfully in municipal water systems similar to the City of Cleveland.

- D. If sufficient evidence is not provided as part of the bid response, the bidder must provide said evidence within 7 calendar days after request/notification to do so.

**C-6 SUBMITTALS**

The bidder shall submit sufficient evidence that the proposed items to be purchased meet all City requirements. Approval shall not relieve the bidder of any obligations in connection with this Contract, including the material and performance requirements thereof. Approved submittals and these specifications are intended to be explanatory of each other. Should any discrepancy later be found, the specifications shall govern. The Director of Public Utilities may make any corrections, errors, or omissions in the documents when such correction is necessary for the proper fulfillment of the specifications. All requested submittals shall be 8-½ inch by 11-inch schematics with the required detail.

Submittals may include the following.

- A. Plans, drawn to scale of not less than 1-½ inch to the foot, clearly showing the material, dimensions, and construction of the products bid upon, and the different parts thereof. Whenever possible, actual shop drawings are preferred.
1. All dimensions and thickness of metal must be written on the drawings, and the kinds of materials to be in each and every part of the construction shall be clearly indicated.
  2. All clearances, weights of each diameter valve, finished surfaces, connections, character or workmanship, and all special devices, etc., shall be so far described or shown as to allow satisfactory evaluation of the strength and durability and ease of operation of the items offered by various bidders.
  3. Shop drawings shall be manufacturer generated detailed, fully dimensioned, complete working drawings, showing thicknesses, weight, direction of turning, type, and specification of materials, exc.
- B. Marked specification noting the proposed items compliance, or exceptions, with all sections listed in these specifications. Any deviation or exception not noted at pertinent paragraph may cause submittal to be rejected.
- C. Manufacturer's cut sheets describing the valve and actuator in detail and proving compliance with these specifications. Providing notes on cut sheets to refer to pertinent valve specification sections is recommended.

**SPECIFICATIONS/DESCRIPTIONS OF PRODUCTS AND/OR SERVICES  
DEPARTMENT OF PUBLIC UTILITIES – DIVISION OF WATER**

**SECTION C – SUPPLEMENTAL GENERAL CONDITIONS  
VALVES AND APPURTENANCES 20-INCH AND LARGER RE-BID**

- D. Operation and maintenance manuals including assembly drawings, alignments, tolerances, and other requirements or notes to maintain if valve is disassembled/reassembled.
- E. Any literature submitted must include the minimum working pressure, the minimum test pressure, and the material composition of the stainless-steel tapping sleeves.

The City shall evaluate all submitted evidentiary material to determine if the proposed valves and appurtenances meet the City's standards. After contract award, the City may require the contractor to modify the drawings as necessary to suit the City's needs, including submitting the drawings in electronic, vectorized, or AutoCAD format.

**C-7 LENGTH OF CONTRACT**

The requirement contract shall be for a period of 1 year. The City has the option to terminate the requirement contract at any time, pursuant to B-10 Cancellation of Contract

**C-8 QUANTITIES TO BE PURCHASED**

The approximate quantities of valves and appurtenances to be purchased under the terms of this requirement contract(s) shall be as set forth on the attached Bid - Schedule of Items.

**C-9 MATERIAL REQUIREMENTS (Lead Free Definition)**

All material covered in this specification shall be "Lead Free". "Lead free" is defined as not more than a weighted average of 0.25 percent lead when used with respect to the wetted surfaces of the materials specified herewith. The weighted average lead content of the materials specified herewith shall be calculated by using the following formula: For each wetted component, the percentage of lead in the component shall be multiplied by the ratio of the wetted surface area of that component to the total wetted surface area of the entire product to arrive at the weighted percentage of lead of the component. The weighted percentage of lead of each wetted component shall be added together, and the sum of these weighted percentages shall constitute the weighted average lead content of the materials specified herewith. The lead content of the material used to produce wetted components shall be used to determine compliance with this specification. For lead content of materials that are provided as a range, the maximum content of the range shall govern.

**C-10 WORKMANSHIP**

The workmanship and all materials used in the assembly of the valves and appurtenances, or any part thereof, shall be first class of the best quality of the kind specified. CWD reserves the right to reject any valves and appurtenances of inferior material or workmanship, which make them unfit for the use for which they are intended.

**SPECIFICATIONS/DESCRIPTIONS OF PRODUCTS AND/OR SERVICES  
DEPARTMENT OF PUBLIC UTILITIES – DIVISION OF WATER**

**SECTION C – SUPPLEMENTAL GENERAL CONDITIONS  
VALVES AND APPURTENANCES 20-INCH AND LARGER RE-BID**

**C-11 COMPLIANCE REQUIREMENTS**

**A. AFFIDAVIT OF COMPLIANCE**

When requested by CWD, the Contractor shall provide an affidavit stating that the valve and all materials used for its construction conform to the requirements herein, that the tests specified herein have been performed, and that all test requirements have been met. The Contractor shall include a brief description of the testing performed and the results of the testing.

**B. CHEMICAL ANALYSIS**

Chemical analysis of the material used shall be furnished by the Contractor to CWD whenever required.

**C-12 MODEL NUMBER**

Bidders must state on the Bid - Schedule of Items pages where indicated, the name of the manufacturer and model number for each item where applicable.

**C-13 APPURTENANCES**

All valves shall have CWD standard sized operating nuts and all other accessories and appurtenances.

**C-14 WEIGHT**

Bidders must state on the Bid - Schedule of Item pages where indicated, the average weight in pounds.

**C-15 REQUIREMENTS FOR SPECIAL PARTS OR SPECIAL SIZE VALVES & APPURTENANCES (Item 22)**

Prior to CWD placing an order for special parts or special sized valves & appurtenances bidder must submit drawings, specifications, and a price quotation for review and approval by CWD.

- A. Bidder will be required to confirm the price quotation by providing a copy of the invoice showing cost to bidder at the time of quote.
- B. A markup will be allowed for those situations when a catalog or price list is not applicable; a part or special sized valve or appurtenance must be fabricated or only the invoice cost to the bidder is available. The markup factor will be multiplied by the estimated allowance and the result will determine the extension that will be added to the total bid.
- C. The bidder will be allowed a maximum 25 percent (%) markup.

**SPECIFICATIONS/DESCRIPTIONS OF PRODUCTS AND/OR SERVICES  
DEPARTMENT OF PUBLIC UTILITIES – DIVISION OF WATER**

**SECTION C – SUPPLEMENTAL GENERAL CONDITIONS  
VALVES AND APPURTENANCES 20-INCH AND LARGER RE-BID**

- D. Bidders shall state percentage (%) markup and extension of allowance in the Bid - Schedule of Items.

**C-16 MATHEMATICAL ERRORS**

If a bidder makes any mathematical errors in the bid sheets such that some or all the bid numbers are mathematically inconsistent with each other, the City shall correct such errors as follows.

- A. The lowest level values or unit prices shall be deemed as indicating the bidder's true intent and shall be accepted as correct.
- B. All further calculations shall then be corrected, and these corrected values shall be cascaded throughout the entire set of bid sheets, potentially affecting the bidder's final bid price.
- C. Calculations subject to such correction include, but are not limited to:
  - 1. Summation of labor and material unit prices into a total unit price.
  - 2. Multiplication of unit price by quantity to arrive at the extension cost.
  - 3. Summation of individual line items into totals or subtotals.
  - 4. Multiplication of any subtotals or other values by contingency percentages or other factors, if a contingency applies.
  - 5. The transferring of subtotals or values from one sheet to another.

If the correction of any errors has an effect on the award of the Contract, only the directly affected bidders will be notified, in writing, of the corrections and their affect.

**C-17 INSPECTION**

A CWD authorized representative shall have the right to inspect the material and work done, as the interest of the City may require.

- A. When requested by CWD, a CWD authorized representative shall have unrestricted access to the manufacturer's plants and all parts of the work, and other places, at which preparation, and construction, of the items to be purchased under the terms of these specifications are carried on. The CWD authorized representatives shall receive all facilities and assistance to carry out their work, inspection, and testing in a satisfactory manner to CWD.
- B. Such an inspection shall not relieve the bidder from any obligation to perform said work in strict accordance with good work practices; to produce a product in compliance with these specifications. Products not so furnished, damaged, and/or non-functioning shall be removed and made good by the bidder at their own expense, free of all expense to the City, and without reference to any previous oversight, acceptance, or error in inspection.

**SPECIFICATIONS/DESCRIPTIONS OF PRODUCTS AND/OR SERVICES  
DEPARTMENT OF PUBLIC UTILITIES – DIVISION OF WATER**

**SECTION C – SUPPLEMENTAL GENERAL CONDITIONS  
VALVES AND APPURTENANCES 20-INCH AND LARGER RE-BID**

- C. The inspection of all materials to be purchased under the terms of this requirement contract will be made by CWD, or the duly authorized representative, without cost to the bidder.

**C-18 EXPERIMENTAL APPARATUS PROHIBITED**

When requested by CWD, each bidder shall submit proof that each and every part of the product which they propose to furnish is of the form and type that has been advertised for sale and has demonstrated practicality and effectiveness, by test and actual use, in successful and practical service outside the bidder's work.

**C-19 NOTICE TO PROCEED**

The language anywhere else in this contract notwithstanding, the term of this contract shall begin when CWD issues a Notice to Proceed (NTP) to the vendor(s). At the City's discretion, the City may shorten the term of this contract by as much as 2 weeks, in order to accomplish an orderly inventory of material. A NTP shall not be issued until the contract has been fully executed and delivered to all parties.

**C-20 DELIVERY** (Supplement to General Conditions Section B-14)

After this Contract has been awarded and a Delivery Order has been issued by the Commissioner of Purchases and Supplies, deliveries may proceed.

Delivery shall be made to the CWD Central Warehouse between 8:00 AM and 3:00 PM Monday-Friday, excluding City holidays.

Central Warehouse  
4300 Harvard Ave. Gate 2  
Entrance Located on E 42<sup>nd</sup> St.  
Newburgh Heights, Ohio 44105

The unit bid price shall include all costs of delivery.

CWD requires a minimum of 24 hours' advance notice of all deliveries. To provide notice in advance of delivery, contact 216-348-7277 ext. 73600.

**C-21 INVOICING** (Supplemental to General Conditions Section – B-21)

The vendor shall submit invoices that appropriately reflect the work performed. Each invoice shall include the manufacturer and part number, the exact itemized cost of each part, the date of order, the date of shipment, listed price, description of item, quantity, and applicable discount and extension; to include CWD's actual cost. Invoices must be typed and legible. Each invoice must be mailed as specified below.

**SPECIFICATIONS/DESCRIPTIONS OF PRODUCTS AND/OR SERVICES  
DEPARTMENT OF PUBLIC UTILITIES – DIVISION OF WATER**

**SECTION C – SUPPLEMENTAL GENERAL CONDITIONS  
VALVES AND APPURTENANCES 20-INCH AND LARGER RE-BID**

- A. Original invoice to the Division of Water, ATTN: Payables Unit, 1201 Lakeside Avenue, 4<sup>th</sup> Floor South, Cleveland, OH 44114 or [payables\\_unit@clevelandwater.com](mailto:payables_unit@clevelandwater.com).
- B. A detailed itemization of materials or services provided, including:
  - 1. Date that CWD gave the work assignment to the vendor.
  - 2. CWD Release/Work Order Number for each individual release.

Failure to deliver copies of invoices to the indicated locations may lead to delays in payment.

**C-22 PAYMENT** (Supplemental to General Conditions Section – B-21)

The vendor must adhere to the terms set forth under sections C-19 Delivery and C-20 Invoicing of this specification.

- A. To ensure accuracy in invoicing, CWD will perform cross-checks utilizing the following four documents.
  - 1. Relevant sections of the Vendor's Contract (e.g., the Bid - Schedule of Items section).
  - 2. A City delivery order (DO) that authorized the specific services/materials being invoiced.
  - 3. Delivery documentation with an acknowledgement signature and date from a CWD employee (e.g., Proof of Service/Delivery slip, Packing Slip, etc.).
  - 4. An accurate invoice.
- B. The vendor is responsible for providing the delivery documentation at the time of delivery and for submitting the invoice; the City will provide the Contract and DO copies.
- C. The vendor must provide firm documentation of manufacturer's list price for item(s) being purchased at the time of transaction or with invoice i.e., the vendor will submit a photocopy of manufacturer's specific price page(s) and identify where the item(s) appears. The vendor will then apply their quoted discount to arrive at CWD's actual cost.
- D. All invoices must include both manufacturer's list price and CWD cost after discount is applied. The vendor is advised that invoices will not be paid unless they are submitted as specified.
- E. CWD shall pay the vendor for all material purchased under this contract at the vendors' specified price, minus discount quoted.
- F. CWD will not assume or pay for material handling, cartage fees or taxes. The vendor assumes this liability solely. No separate delivery charges shall be considered or paid.

If all is in order (e.g., delivered/invoiced items were authorized under the contract and DO, invoiced quantities were delivered, contract prices were invoiced, discounts applied, etc.) CWD will approve payment of the invoice through the City's internal processes. The City's Division of

**SPECIFICATIONS/DESCRIPTIONS OF PRODUCTS AND/OR SERVICES  
DEPARTMENT OF PUBLIC UTILITIES – DIVISION OF WATER**

**SECTION C – SUPPLEMENTAL GENERAL CONDITIONS  
VALVES AND APPURTENANCES 20-INCH AND LARGER RE-BID**

Accounts subsequently handles processing of the payment request, and the Division of Treasury issues the payment.

**C-23 OEO PARTICIPATION GOALS** (Supplemental to A-17, A-18, and B-23)

Under Chapter 187.13C of the Codified Ordinances, the OEO participation goal for this requirement contract(s) has been waived. Schedules 1-4 are not required.

There is no Subcontractor Participation (Utilization) Goal for this contract. However, per Section A-19(a) of the Instructions to Bidders, any and all proposed subcontractors, whether City certified or not, must be divulged and listed in the sealed bid. If you plan to utilize a subcontractor, submit a proposed subcontractor list on a separate, signed sheet of paper, listing the name, address, type of work or materials, and total subcontractor amount for each and every subcontractor that you propose to use on this contract.

You are encouraged to consider City-certified firms for any available subcontracting opportunities. A searchable database of all City-certified firms can be found on the City of Cleveland Office of Equal Opportunity Website:

<http://cleveland.diversitycompliance.com>

On the website, click on Search Certified Directory.

**SPECIFICATIONS/DESCRIPTIONS OF PRODUCTS AND/OR SERVICES  
DEPARTMENT OF PUBLIC UTILITIES – DIVISION OF WATER**

**SECTION D – TECHNICAL SPECIFICATIONS  
VALVES AND APPURTENANCES 20-INCH AND LARGER RE-BID**

**D-1 DEFINITIONS/STANDARDS**

Valves furnished under this item shall be manufactured in accordance with the applicable AWWA minimum standards and in accordance with the supplemental requirements of these specifications. Size and type of valves shall be as specified herein and indicated in the Bid – Schedule of Items. Standards referenced herein shall be the latest revision thereof, except as modified herein.

- A. AWWA C110: DUCTILE-IRON AND GRAY-IRON FITTINGS.
- B. AWWA C111: RUBBER-GASKET JOINTS FOR DUCTILE-IRON PRESSURE PIPE AND FITTINGS.
- C. AWWA C203: COAL-TAR PROTECTIVE COATINGS AND LININGS FOR STEEL WATER PIPELINES - ENAMEL AND TAPE – HOT- APPLIED.
- D. AWWA C219: BOLTED, SLEEVE-TYPE COUPLINGS FOR PLAIN-END PIPE.
- E. AWWA C500: METAL-SEATED GATE VALVES FOR WATER SUPPLY SERVICE.
- F. AWWA C509: RESILIENT-SEATED GATE VALVES FOR WATER SUPPLY SERVICE.
- G. AWWA C515: REDUCED-WALL, RESILIENT-SEATED GATE VALVES FOR WATER SUPPLY SERVICE.
- H. AWWA C550: PROTECTIVE INTERIOR COATINGS FOR VALVES AND HYDRANTS.
- I. AWWA C606: GROOVED AND SHOULDERED JOINTS.
- J. ASME B16.1: GRAY IRON PIPE FLANGES AND FLANGED FITTINGS: CLASSES 25, 125, AND 250.
- K. ASME B16.5: PIPE FLANGES AND FLANGED FITTINGS: NPS ½ THROUGH NPS 24 METRIC/INCH STANDARD.
- L. ASTM A126: STANDARD SPECIFICATION FOR GRAY IRON CASTINGS FOR VALVES, FLANGES, AND PIPE FITTINGS.
- M. ASTM A193: STANDARD SPECIFICATION FOR ALLOY-STEEL AND STAINLESS-STEEL BOLTING FOR HIGH TEMPERATURE OR HIGH-PRESSURE SERVICE AND OTHER SPECIAL PURPOSE APPLICATIONS.
- N. ASTM A194: STANDARD SPECIFICATION FOR CARBON AND ALLOY STEEL NUTS FOR BOLTS FOR HIGH PRESSURE OR HIGH TEMPERATURE SERVICE, OR BOTH.
- O. ASTM A276: SPECIFICATION FOR STAINLESS STEEL BARS AND SHAPES.



**SPECIFICATIONS/DESCRIPTIONS OF PRODUCTS AND/OR SERVICES  
DEPARTMENT OF PUBLIC UTILITIES – DIVISION OF WATER**

**SECTION D – TECHNICAL SPECIFICATIONS  
VALVES AND APPURTENANCES 20-INCH AND LARGER RE-BID**

assembled. Reduced port or venturi port waterway valves are not acceptable.

**D-5 DIRECTION OF OPENING**

All gate valves, including bypass valves, shall open by turning in a clockwise direction when viewed from the top.

**D-6 TYPES OF VALVES**

AWWA C509 and C515 gate valves shall be of the resilient-seated type. AWWA C500 gate valves shall be of the metal-seated type. Gate Valves shall be of the size and joint type shown in the Bid - Schedule of Items.

**D-7 CASTINGS/MACHINING/FITS/HARDWARE**

All castings shall be ductile iron, clean and sound, without defects which impair their service or reduce longevity. Shrinks, porosity, hot tears, cold shuts, cracks, inclusions, coarse structure, and gas holes shall be determined and repaired before the castings are assembled. Repairing of structural defects is not allowed unless agreed to by the Engineer. All shafts and machined contact, or bearing surfaces, shall have an ISO N7, 125 micro inch Ra finish without grooves, surface imperfections, or machining marks of any sort. Internal alignment is critical, and all moving components and shafts shall have centerlines designed to provide alignment for correct valve operation without looseness nor increase in operating torque.

**A. MACHINED PARTS**

All machined bolts, nuts, and cap screws shall be of the hex-head type and shall not require the use of any special tools.

1. Uncoated mating machined surfaces shall be coplanar within a maximum of 0.002 inches.
2. Mating machined surfaces that are to be coated by fusion bonded epoxy shall be coplanar within a maximum of 0.005 inches.

**B. MAXIMUM TOLERANCE**

Maximum tolerance for stem, bonnet, bonnet cover, and wedge nut alignment shall not exceed 3/64 of an inch.

**C. SURFACE ROUGHNESS**

All castings shall be of high quality with no surface or internal imperfections. Surface roughness of external cast surfaces shall be 560 micro-inch RMS, or better, prior to surface preparation for coating.

**D. INTERNAL SURFACE ROUGHNESS**

Internal surfaces shall have an internal surface roughness of 420 micro-inch RMS, or better, prior to surface preparation for coating.

**SPECIFICATIONS/DESCRIPTIONS OF PRODUCTS AND/OR SERVICES  
DEPARTMENT OF PUBLIC UTILITIES – DIVISION OF WATER**

**SECTION D – TECHNICAL SPECIFICATIONS  
VALVES AND APPURTENANCES 20-INCH AND LARGER RE-BID**

**E. REPAIRS**

Repairs shall be checked using the same method used to identify them. Repairs shall result in continuous metal structure with no interfaces between original and repair metal for the repair to be acceptable. If defects are substantial such that structural integrity or longevity of the product is affected prior to or after repairs, then repairs shall not be acceptable, and a new casting shall be provided. If total repair metal is more than 1% of the casting volume or surface area, then the casting shall be rejected and will be replaced.

**D-8 RETAINED MECHANICAL JOINT ENDS**

All valves requiring mechanical joint ends shall be furnished with Retained Mechanical Joint ends complete with gaskets and retainer type glands and shall fit the plain end of ductile iron pipe. Bell dimensions shall conform to AWWA C111. Fasteners shall be made of stainless steel, Type 304L.

**D-9 BOLTLESS RESTRAINED PUSH-ON JOINT ENDS**

All valves requiring push-on joint ends shall be furnished with Boltless Restrained Push-on Joint ends conforming to AWWA C111.

**D-10 FLANGED JOINT ENDS**

Flanges shall be flat faced. All valves requiring flanged ends shall conform to drillings of ASME B16.1, "class 125" but rated for 250 psi as shown in the Bid - Schedule of Items. Other dimensions and drilling of end flanges or flanged valves shall conform to ANSI/AWWA C207 Class E or F, or ANSI/AWWA C110. Castings and machining shall be as described in section D-7 Castings, Machining, Fits and Hardware. Flanged joints intended to be watertight shall have rubber O-ring type gaskets. Fasteners shall be made of stainless steel, Type 304L.

**A. DUCTILE IRON THICKNESS**

The thickness of ductile-iron end flanges may not be less than specified in ASME B16.1 or ANSI/AWWA C110.A21.10 and AWWA C515.

**B. BOLT HOLES**

Bolt holes shall be spot faced if the flange is more than  $2 \pm 0.5$  degrees from flat, or the thickness exceeds the required minimum flange thickness by more than indicated in AWWA C500, AWWA C509, and AWWA C515, respectively.

1. Spot-facing shall be done in accordance with the Manufacturers Standardization Society (MSS) Standard Practices, SP-9.
2. Bolt holes shall straddle the vertical centerline of the valve.

**C. NON-COATED SURFACES**

Surfaces that are not coated with fusion bonded epoxy and are in contact with a gasket shall have the customary concentric grooves pattern to increase leak path.

**SPECIFICATIONS/DESCRIPTIONS OF PRODUCTS AND/OR SERVICES  
DEPARTMENT OF PUBLIC UTILITIES – DIVISION OF WATER**

**SECTION D – TECHNICAL SPECIFICATIONS  
VALVES AND APPURTENANCES 20-INCH AND LARGER RE-BID**

**D-11 MATERIAL**

- A. All stainless-steel parts, including bolts and nuts, shall conform to ASTM A276, Type 304L.
- B. Ductile iron shall conform to ASTM A536.
- C. Copper alloy (bronze) is only acceptable in the body seat rings, gate rings, and sleeve bushing. All grades of copper alloy shall be in accordance with AWWA C500, AWWA C509, and AWWA C515 respectively, unless otherwise specified herein.
- D. O-ring gaskets shall conform to ASTM D2000 and have physical properties suitable for the application.
- E. Elastomers used for resilient seats shall conform to AWWA C509 and AWWA C515 respectively, unless otherwise specified herein.

All other materials used in the manufacture of these valves and not specified in the specifications, shall be subject to inspection, tests, and approval by the Engineer.

**D-12 COATINGS**

- A. For all AWWA C509 valves, all interior and exterior ferrous surfaces of the body and bonnet, except finished or bearing surfaces, shall be fusion bonded epoxy coated in accordance with AWWA C550. All AWWA C500 rolling double disc valves are to be coated with a two-part thermosetting epoxy complying with AWWA C550.
- B. The exterior ferrous surfaces of all valves shall be coated using the same coating and process as shown for the interior above.
- C. All iron castings shall be thoroughly cleaned on the outside and inside surfaces and protected from rain or moisture until they are coated.
- D. All external 304L stainless steel fasteners on buried or underground valves and the associated flanges, mechanical joints or end connections shall be coated with two coats of Bitumastic as specified in section B.

**D-13 MARKING**

All gate valves 20-inch and larger shall have the manufacturer's name or mark, year working pressure ("250W"). A permanent bronze or stainless-steel tag affixed to the valve containing such information may be provided in lieu of raised letters. Similarly, a permanent bronze or stainless-steel tag shall be affixed to the inside of the upper section of the valve box in an easily visible location stating valve type, size, number the valve casting was made, size of the valve, AWWA designation and rated of turns to open and direction of opening.

**SPECIFICATIONS/DESCRIPTIONS OF PRODUCTS AND/OR SERVICES  
DEPARTMENT OF PUBLIC UTILITIES – DIVISION OF WATER**

**SECTION D – TECHNICAL SPECIFICATIONS  
VALVES AND APPURTENANCES 20-INCH AND LARGER RE-BID**

**D-14 APPURTENANCES**

**D-14.1 OPERATING NUT**

The operating nuts shall be made of stainless steel and shall be standard tapered CWD sizes, 1-7/8-inch square at base and 1-3/4 inch deep, and shall be secured to the stem by a pinned shaft key, bronze retaining nut or stainless-steel bolt. Shaft key and pin must be coated after installation with a Bitumastic coating or equal to protect against corrosion. Adjustment to actuator mechanism must be done if needed to cause operator nut to be plum. Valve nut operator shall be within 4 degrees from vertical regardless of pipe slope.

**D-14.2 ACTUATORS AND GEARING**

All actuators, extension rods, gears, and multi-turn gearboxes and their accessories shall be sized for 3 times the maximum torque at the **maximum pressure differential. For the purposes of this bid, maximum pressure differential is 250 psi.**

Connection of extension rods, actuators, gear boxes and valves shall be through shaft splines, keys, flanges, or similar device fixed and protected as required per design type and per the torque rating stated above. The torque rating factor of safety used in the actuator and gear sizing shall be determined by the valve manufacturer, not sales representative or distributor and calculations shall be provided in writing with submittal. All gears shall be AGMA Q10 or better.

**A. GEARSET NUMBER**

The gear and pinion set shall be manufactured and tested as a set with a gearset number. Gear and pinion with different gearset numbers are not acceptable.

1. Install using gear manufacturer's mounting distance, matched teeth, and backlash.

**B. GEAR RATIO**

Gear ratios shall not be less than those shown in AWWA C500, AWWA C509, and AWWA C515 for the respective gate types.

**C. GREASE CASE**

Gears shall be enclosed in a watertight grease case.

1. All grease cases shall be provided with a removable cover securely bolted in place to allow easy access to the gears, and convenient filling and draining plugs.
2. The valves shall be furnished and delivered with the grease cases filled with the proper lubricant as recommended by the manufacturer.

**D. GEAR BOXES/ACTUATORS**

Third party gear boxes or actuators shall be connected to the valve by the manufacturer and shall meet the above requirements.

**E. VALVE ACTUATOR TESTING**

Testing must be witnessed by the City or its representative before valve actuator acceptance. Witnesses via teleconference are acceptable.

**SPECIFICATIONS/DESCRIPTIONS OF PRODUCTS AND/OR SERVICES  
DEPARTMENT OF PUBLIC UTILITIES – DIVISION OF WATER**

**SECTION D – TECHNICAL SPECIFICATIONS  
VALVES AND APPURTENANCES 20-INCH AND LARGER RE-BID**

**D-14.3 BYPASS**

All valves 20-inch and larger shall have bypasses. The bypasses shall be located on or below the horizontal centerline of the valves. The bypass valve and piping shall be attached directly to the gate valve body. Bypass valves shall be of the same size as the bypass piping and shall be double disc gate valves or resilient-seated gate valves conforming to the requirements of these specifications for gate valves. Bypasses shall be sized as follows.

Valve Size (inch)	Minimum Bypass Size (inch)
20 - 30	4
36 - 42	6
48 and larger	8

Manufacturers shall certify that the provided size is sufficient to equalize pressure based on full differential at the pressure rating.

**D-15 VALVE ORIENTATION AND VALVE BOX SET**

For buried valves where the top of the valve operating nut exceeds a 4-foot depth, the gate valve shall be furnished and installed with a valve stem extension sized to three times the maximum torque at the highest-pressure differential.

**A. VERTICAL GATE VALVE WITH VALVE BOX SET**

Gate Valve with Valve Box Complete shall be furnished as a set, boxed together and as listed in the Bid – Schedule of Items. Gate valve shall be a rolling double-disc or resilient-seated gate valve conforming to these specifications for vertical gate valves, including the supplemental requirements thereof as specified herein. Extension rod shall be of the proper length conforming to the detail shown on Figure A.

Valves 20-inch and larger are rarely installed orientated vertically to prevent water from freezing in the valve bodies. If necessary, the valve may be set in a manhole, similar to Figure B, with the valve oriented vertically.

**SPECIFICATIONS/DESCRIPTIONS OF PRODUCTS AND/OR SERVICES  
DEPARTMENT OF PUBLIC UTILITIES – DIVISION OF WATER**

**SECTION D – TECHNICAL SPECIFICATIONS  
VALVES AND APPURTENANCES 20-INCH AND LARGER RE-BID**

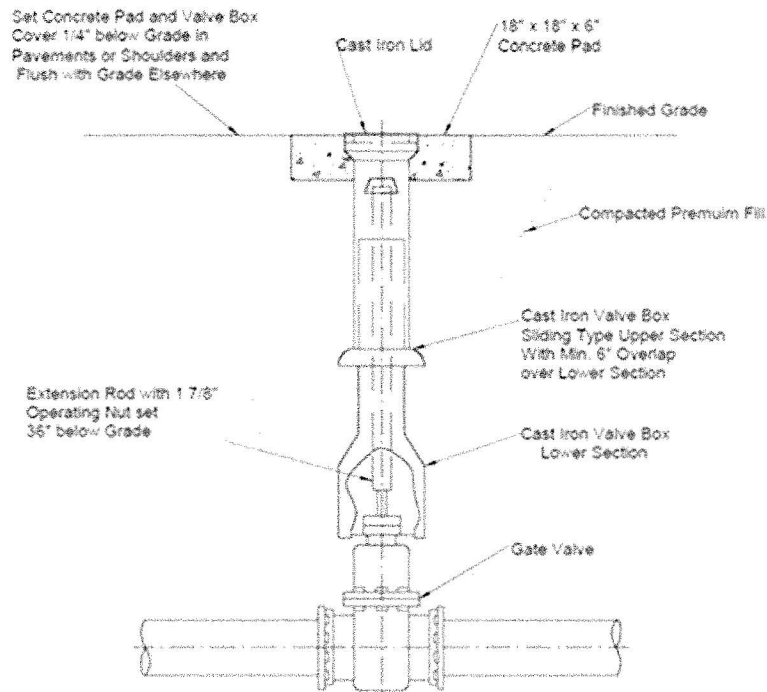

Figure A: Vertical Gate Valve Detail

**B. HORIZONTAL GATE VALVE AND VALVE BOX SET**

Horizontal Gate Valve with Bypass Valve and Valve Box Complete shall be furnished as a set, boxed together and as listed in the Bid - Schedule of Items. Horizontal gate valves shall be rolling double-disc or resilient-seated conforming to these specifications for horizontal gate valves, including the supplemental requirements thereof as specified herein. The bypass valve may be either a rolling double-disc or resilient-seated gate valve as specified herein. Horizontal Gate Valves shall be of the size noted in the Bid - Schedule of Items and shall be furnished with valve box complete.

Extension rod shall be of proper length conforming to the detail shown on Figure B. The bypass gate valve shall be furnished and installed with a valve stem extension of the proper length. All valves specified to be installed horizontally shall be equipped with steel bevel gears.

**SPECIFICATIONS/DESCRIPTIONS OF PRODUCTS AND/OR SERVICES  
DEPARTMENT OF PUBLIC UTILITIES – DIVISION OF WATER**

**SECTION D – TECHNICAL SPECIFICATIONS  
VALVES AND APPURTENANCES 20-INCH AND LARGER RE-BID**

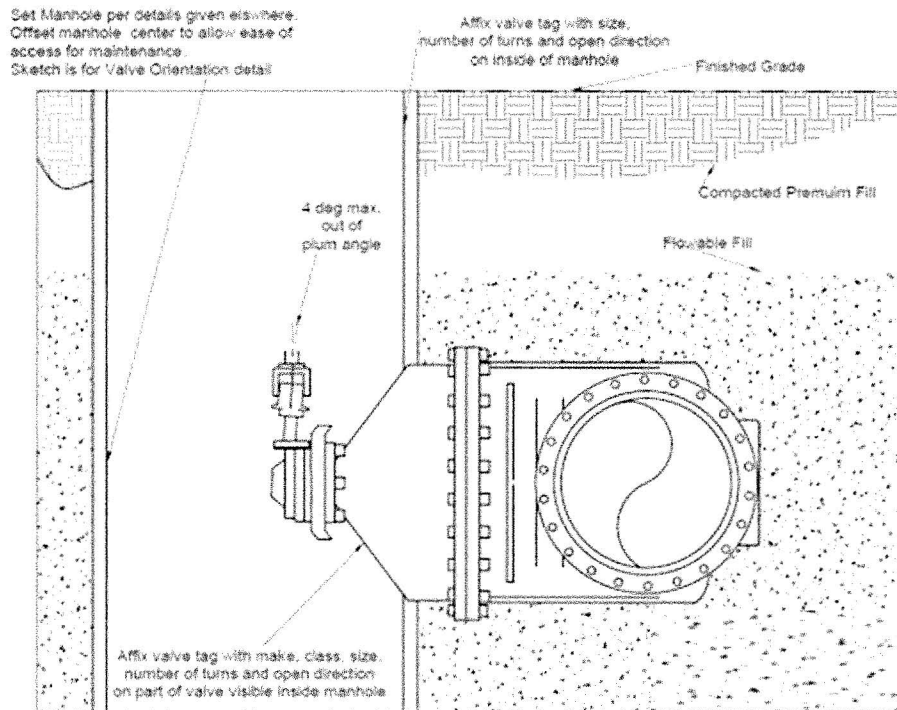

Figure B: Horizontal Gate Valve – Manhole Option

**D-16 DOUBLE DISC GATE VALVES**

The rolling double disc gate valves shall be manufactured in full compliance with AWWA C500 and shall comply with the supplementary requirements specified herein. Gate valves shall be of the rolling double-disc parallel seat type.

**D-16.1 OPERATION**

In opening or closing the valve, the gates shall be forced to ascend or descend by reason of the thrust exerted upon the gates directly by the valve stem wrench nut, this thrust being generated by the rotation of the valve stem. In closing the valve, the gates/discs move or roll freely without friction until opposite the ports. Physical stops are used to set travel limits. The discs/gates are then pressed firmly against the body seats by wedges or some other device of equally suitable and approved means.

The design of the mechanical wedging action shall be such that seating force is applied equally to multiple contact points near the outer edge of each. The mechanism shall cause all wedging members to be activated at the same time. Unbalanced seating pressure is not acceptable.

**D-16.2 STRUCTURAL DESIGN**

Valves shall be designed to withstand an internal test pressure of twice the rated working pressure of the valve and withstand the rated working pressure when the gate is cycled from fully open to fully close against the rated unbalanced working pressure. The valve assembly and mechanism

**SPECIFICATIONS/DESCRIPTIONS OF PRODUCTS AND/OR SERVICES  
DEPARTMENT OF PUBLIC UTILITIES – DIVISION OF WATER**

**SECTION D – TECHNICAL SPECIFICATIONS  
VALVES AND APPURTENANCES 20-INCH AND LARGER RE-BID**

shall be capable of withstanding input torques provided in AWWA C500 and as required in these specifications with a minimum factor of safety of three.

**A. BODY AND BONNET**

Bodies and bonnets for double disc gate valves shall be ductile iron. Shell thickness shall be in accordance with AWWA C500.

**B. GATE AND GATE RING**

The gate shall be made of ductile iron in accordance with AWWA C500. Gate rings shall be made of ASTM Series C95000 Aluminum Bronze or Nickel Aluminum Bronze in accordance with Table 6 of AWWA C500. Gate rings shall be attached to the gate by threading or may be rolled, peened, or pressed into grooves machined in the discs. The faces shall be machined to a smooth finish after they have been fully secured in place.

**C. BODY-SEAT RINGS**

The body-seat rings shall be made of ASTM SERIES 95000 Aluminum Bronze or Nickel Aluminum Bronze in accordance with Table 6 of AWWA C500. The rings shall have accurately cut threads and shall be screwed into machined seats in the valve body. The face in contact with the gate ring shall be machined to a smooth finish.

**D. BOLTING**

Bolts and nuts on the external valve bodies, valve flanges and tapping flanges shall be made of stainless steel, Type 304L. Threads shall be coated with an anti-seize compound.

**E. STEM AND STEM NUT**

The stem shall be made from 304L stainless steel, and the stem nut shall be made from a non-galling stainless steel with minimum stem diameters and number of turns to open in accordance with AWWA C500. All gate valves shall have non-rising stems (NRS) with integral thrust collars. The stem opening and thrust bearing recess shall be bronze or stainless steel bushed for valves 20-inch and larger.

**F. STEM SEALING**

The sealing system shall be designed to be watertight at the rated working pressure of the valve. The stuffing box shall be of the O-ring type, with two O-rings located above the thrust collar and one O-ring located below the thrust collar. The stuffing box shall be designed so that the two O-rings above the thrust collar can be replaced with the valve under pressure in the fully open position. On valves 20-inch and larger, the stuffing boxes shall be separate from the bonnet.

**G. DISC-SPREADING DEVICES**

Wedge surfaces shall be made from stainless steel in accordance with AWWA C500.

**H. TRACKS AND SCRAPERS**

All double disc gate valves 20-inch and larger shall have solid stainless-steel tracks and the discs shall serve as rollers. Tracks and scrapers shall be included on both sides of the valve such that the valve is properly installed regardless of valve orientation.

**SPECIFICATIONS/DESCRIPTIONS OF PRODUCTS AND/OR SERVICES  
DEPARTMENT OF PUBLIC UTILITIES – DIVISION OF WATER**

**SECTION D – TECHNICAL SPECIFICATIONS  
VALVES AND APPURTENANCES 20-INCH AND LARGER RE-BID**

**I. SHOP TESTING**

All gate valves shall be subjected to an operation test and a hydrostatic test at the manufacturer's plant as specified herein. The manufacturer shall furnish a sworn statement that the inspection and all specified tests have been completed and that results comply with the requirements of these Standards. A copy of the Certification, including compliance with NSF/ANSI 61, shall be provided.

1. For the operation test, each valve shall be positioned horizontally or vertically to match the design position and operated through a complete cycle to ensure proper functioning of all parts. Any defects in workmanship shall be corrected by the Contractor at his expense, to the satisfaction of CWD, and the test repeated until a satisfactory performance is demonstrated.
2. For the hydrostatic test, a hydrostatic pressure equal to twice the rated working pressure of the valve shall be applied between the discs with the gate in the closed position. The test shall show no leakage through the metal, pressure-containing joints, or stem seals. The duration of the test shall be 15 minutes for valves 20-inch through 24-inch, and 30 minutes for valves 30-inch and larger. The hydrostatic test shall then be performed again at the rated working pressure, applied between the discs with the gate in the closed position. Leakage by either seat during the second test shall not exceed a rate of 1 oz. /hr. /in. of nominal valve size. The Test shall be repeated from the other side.

**D-17 RESILIENT-SEATED GATE VALVES**

The resilient-seated gate valves shall be manufactured in full compliance with AWWA C509 and shall comply with the supplementary requirements specified herein. Valves 36-inch and larger shall be designed with three-piece construction; consisting of a body, body spacer, and bonnet to provide ease of disassembly in the field if service should ever be required.

**D-17.1 STRUCTURAL DESIGN**

Valves shall be designed to withstand an internal test pressure of twice the rated working pressure of the valve and withstand the rated working pressure when the gate is cycled from fully open to fully closed against the rated unbalanced working pressure. The valve assembly and mechanism shall be capable of withstanding input torques provided in AWWA C509.

**A. BODY AND BONNET**

Bodies and bonnets for resilient-seated gate valves shall be ductile iron. Shell thickness shall be in accordance with AWWA C509 and AWWA C500.

**B. GATE**

The metal reinforcement of the gate shall be ductile iron in accordance with AWWA C509.

**C. RESILIENT SEAT**

**SPECIFICATIONS/DESCRIPTIONS OF PRODUCTS AND/OR SERVICES  
DEPARTMENT OF PUBLIC UTILITIES – DIVISION OF WATER**

**SECTION D – TECHNICAL SPECIFICATIONS  
VALVES AND APPURTENANCES 20-INCH AND LARGER RE-BID**

The resilient seat shall be bonded to the gate on valves 48-inch and smaller. Valves 54-inch and larger shall have the resilient seat mechanically attached to the gate to allow field adjustability and/or replacement if ever needed. Seat attachment shall comply with AWWA C509.

**D. BOLTING**

Bolts and nuts on the external valve bodies, valve flanges and tapping flanges shall be made of stainless steel, Type 304L or 316L. Threads not in contact with potable shall be coated with an anti-seize compound. Threads in contact with potable water shall have a Teflon tape or other food grade galling protection.

**E. STEM AND STEM NUT**

The stem shall be made from stainless steel and the stem nut shall be made from a non-galling stainless steel with minimum stem diameters and number of turns to open in accordance with AWWA C509. All gate valves shall have non-rising stems (NRS) with integral thrust collars.

**F. STEM SEALING**

The sealing system shall be designed to be watertight at the rated working pressure of the valve. The stuffing box shall be of the O-ring type, with two O-rings located above the thrust collar and one O-ring located below the thrust collar. The stuffing box shall be designed so that the two O-rings above the thrust collar can be replaced with the valve under pressure in the fully open position.

**G. SHOP TESTING**

All gate valves shall be subjected to an operation test, hydrostatic shell test and hydrostatic seat test at the manufacturer's plant as specified herein. The manufacturer shall furnish a sworn statement that the inspection and all specified tests have been completed and that results comply with the requirements of these Standards. A copy of the Certification, including compliance with NSF/ANSI 61, shall be provided.

1. For the operation test, each valve shall be positioned horizontally or vertically to match the design position and operated through a complete cycle to ensure proper functioning of all parts. Any defects in workmanship shall be corrected by the Manufacturer, to the satisfaction of the Engineer, and the test repeated until a satisfactory performance is demonstrated.
2. For the hydrostatic shell test, a hydrostatic pressure equal to twice the rated working pressure of the valve shall be applied to the assembled valve with the gate in the open position. The test shall show no leakage through the metal, pressure-containing joints, or stem seals. The duration of the shell test shall be 5 minutes for valves 20-inch through 24-inch, and 10 minutes for valves 30-inch and larger.
3. For the operation test, each valve shall be positioned horizontally or vertically to match the design position and operated through a complete cycle to ensure proper functioning of all parts. Any defects in workmanship shall be corrected by the manufacturer, to the satisfaction of CWD, and the test repeated until a satisfactory

**SPECIFICATIONS/DESCRIPTIONS OF PRODUCTS AND/OR SERVICES  
DEPARTMENT OF PUBLIC UTILITIES – DIVISION OF WATER**

**SECTION D – TECHNICAL SPECIFICATIONS  
VALVES AND APPURTENANCES 20-INCH AND LARGER RE-BID**

performance is demonstrated.

4. For the hydrostatic shell test, a hydrostatic pressure equal to twice the rated working pressure of the valve shall be applied to the assembled valve with the gate in the open position. The test shall show no leakage through the metal, pressure-containing joints, or stem seals. The duration of the shell test shall be 5 minutes for valves 20-inch through 24-inch, and 10 minutes for valves 30-inch and larger.
5. For the hydrostatic seat test, a hydrostatic test shall be made from each direction with the gate in the closed position at a minimum of the rated working pressure. The test shall show no leakage through the metal, pressure-containing joints, or past the seat. The duration of the seat test for each direction shall be 5 minutes for valves 20-inch through 24-inch, and 10 minutes for valves 30-inch and larger.

**D-18 REDUCED-WALL, RESILIENT-SEATED GATE VALVES**

Resilient-seated gate valves shall be manufactured in full compliance with AWWA C515 and shall comply with the supplementary requirements herein specified.

**D-18.1 STRUCTURAL DESIGN**

Valves shall be designed to withstand an internal test pressure of twice the rated working pressure of the valve and withstand the rated working pressure when the gate is cycled from fully open to fully closed against the rated unbalanced working pressure. The valve assembly and mechanism shall be capable of withstanding input torques provided in AWWA C515.

**A. BODY AND BONNET**

Bodies and bonnets for resilient-seated gate valves shall be ductile iron. Shell thickness shall be in accordance with AWWA C515.

**B. GATE**

The metal reinforcement of the gate shall be made of ductile iron in accordance with AWWA C515.

**C. RESILIENT SEAT**

The resilient seat shall be bonded to the gate in accordance with AWWA C515.

**D. BOLTING**

Bolts and nuts on the external valve bodies, valve flanges and tapping flanges shall be made of stainless steel, Type 304L or 316L. Threads not in contact with potable shall be coated with an anti-seize compound. Threads in contact with potable water shall have a Teflon tape or other food grade galling protection.

**E. STEM AND STEM NUT**

The stem shall be made from stainless steel and the stem nut shall be made from a non-galling stainless steel with minimum stem diameters and number of turns to open in accordance with AWWA C515. All gate valves shall have non-rising stems (NRS) with

**SPECIFICATIONS/DESCRIPTIONS OF PRODUCTS AND/OR SERVICES  
DEPARTMENT OF PUBLIC UTILITIES – DIVISION OF WATER**

**SECTION D – TECHNICAL SPECIFICATIONS  
VALVES AND APPURTENANCES 20-INCH AND LARGER RE-BID**

integral thrust collars.

**F. STEM SEALING**

The sealing system shall be designed to be watertight at the rated working pressure of the valve. The stuffing box shall be of the O-ring type, with two O-rings located above the thrust collar and one O-ring located below the thrust collar. The stuffing box shall be designed so that the two O-rings above the thrust collar can be replaced with the valve under pressure in the fully open position.

**G. SHOP TESTING**

All gate valves shall be subjected to an operation test, hydrostatic shell test and hydrostatic seat test at the manufacturer's plant as specified herein. The manufacturer shall furnish a sworn statement that the inspection and all specified tests have been completed and that results comply with the requirements of these Standards. A copy of the Certification, including compliance with NSF/ANSI 61, shall be provided.

1. For the operation test, each valve shall be positioned horizontally or vertically to match the design operated through a complete cycle to ensure proper functioning of all parts. Any defects in workmanship shall be corrected by the manufacturer, to the satisfaction of CWD, and the test repeated until a satisfactory performance is demonstrated.
2. For the hydrostatic shell test, a hydrostatic pressure equal to twice the rated working pressure of the valve shall be applied to the assembled valve with the gate in the open position. The test shall show no leakage through the metal, pressure-containing joints, or stem seals. The duration of the shell test shall be 5 minutes for valves 20-inch through 24-inch, and 10 minutes for valves 30-inch and larger.
3. For the hydrostatic seat test, a hydrostatic test shall be made from each direction with the gate in the closed position at a minimum of the rated working pressure. The test shall show no leakage through the metal, pressure-containing joints, or past the seat. The duration of the seat test for each direction shall be 5 minutes for valves 20-inch through 24-inch, and 10 minutes for valves 30-inch and larger.

NORTHERN IRELAND FAIR EMPLOYMENT PRACTICES DISCLOSURE

INSTRUCTIONS:  Pursuant to Codified Ordinance Sec. 181.36, the information requested on this page must be supplied by all contractors and any subcontractors having more than a fifty percent (50%) interest in the proposed contract prior to any contract being awarded by the City of Cleveland. Any contractor or subcontractor who is deemed to have made a false statement shall be declared to have acted in default of its contract and shall be subject to the remedies for default contained in its contract. For failure to cure such a default, the contractor or subcontractor shall be automatically excluded from bidding for the supply of any goods or services for use by the City for a period of two (2) years.

CHECK WHICHEVER IS APPLICABLE:

A.   The undersigned or any controlling shareholder,\* subsidiary, or parent corporation of the undersigned is **NOT ENGAGED IN ANY BUSINESS OR TRADING FOR PROFIT IN NORTHERN IRELAND.** (if paragraph A. is checked, proceed to the signature line.)

B.   The undersigned or any controlling shareholder,\* subsidiary, or parent corporation **IS ENGAGED IN ANY BUSINESS OR TRADING FOR PROFIT IN NORTHERN IRELAND.** (if paragraph B. is checked, please either check the stipulation contained in paragraph C. or attach documentation that shows that the undersigned has complied with the stipulation contained in paragraph C.)

C.   The undersigned and all enterprises identified in paragraph B. are **TAKING LAWFUL AND GOOD FAITH STEPS TO ENGAGE IN FAIR EMPLOYMENT PRACTICES WHICH ARE RELEVANT TO THE STANDARDS EMBODIED IN THE "MacBRIDE PRINCIPLES FOR FAIR EMPLOYMENT IN NORTHERN IRELAND."** A copy of the MacBride Principles can be obtained from the Office of the Commissioner of Purchases and Supplies. In lieu of checking this paragraph, the undersigned must attach documentation which the undersigned believes shows compliance with the stipulation contained in this paragraph C.

\_\_\_\_\_  
Name of Contractor or Subcontractor

By: \_\_\_\_\_

Title: \_\_\_\_\_

\* "Controlling shareholder" means any shareholder owning more than fifty percent (50%) of the stock in the corporation or more than twenty-five percent (25%) of the stock in the corporation if no other shareholder owns a larger share of stock in the corporation.

## SUPPLEMENTAL NOTICE TO BIDDERS

**SUBJECT:** Submission  
NORTHERN IRELAND FAIR EMPLOYMENT PRACTICES  
DISCLOSURE

Each bidder and/or appropriate parties should complete the DISCLOSURE and submit it with the bid, if possible. If not submitted with the bid, it must be completed and submitted to the Commissioner of Purchases and Supplies prior to any contract being awarded by the City. If a bidder or appropriate parties fail to complete and submit it, they shall not be eligible for a contract award.



## **WAGE THEFT AND PAYROLL FRAUD DISCLOSURE**

### **SUMMARY:**

Bidders on certain City contracts, recipients of Assistance, and any of their prospective subcontractors must disclose any wage theft or payroll fraud violations over the last three years. Unless they receive a waiver from the City's Fair Wage Employment Board, violators are placed on the City's Adverse Determination List, which prevents them from entering into new contracts with or receiving Assistance from the City. This disclosure requirement and the waiver process are set forth in Chapter 190 of the Codified Ordinances of Cleveland, Ohio, 1976 ("Chapter 190").

### **INSTRUCTIONS:**

Pursuant to Chapter 190, the information requested on this document must be provided by any person or entity bidding on or making a proposal for a Construction or Improvement Contract or a Service Contract, or applying for Assistance, and any of their prospective subcontractors.

Any person or entity that is deemed to have made a false statement shall be declared to have acted in default of its contract and shall be subject to the remedies for default contained in its contract.

### **DEFINITIONS:**

"Adverse Determination" means a final action or adjudication that the person or entity in question has committed Wage Theft or Payroll Fraud and is further defined in Chapter 190.

"Assistance" means any form of City financial assistance, except for financial assistance provided for the development, rehabilitation or other means of providing residential housing. Assistance includes but is not limited to: grants; economic development loans; tax credits, incentives and abatements; subsidies; and bonds. Assistance does not include financial assistance which is received from another government or other entity with the City acting only as a conduit or fiscal agent for the funds, where the City exercises no control over the identity of any recipient or of the terms of the contract. Community Development Block Grant Funds are not considered conduit funds and, to the extent they otherwise qualify, are included as Assistance.

"Construction or Improvement Contract" means any contract entered into pursuant to Chapter 167 or Chapter 185 of the Codified Ordinances.

"Payroll Fraud" means concealing an entity's true payroll tax liability or other financial liability to a government agency from government licensing, regulatory or taxing agencies through misclassification of employees, failure to report or underreported



payment of wages, or executing a cash transaction while failing to maintain proper records of reporting and withholding.

“Service Contract” means any contract or subcontract between a person, business or corporation and the City of Cleveland that primarily involves the furnishing of services to the City (as opposed to the purchase of goods or other property or the leasing of property), and shall be limited to the following categories of services: food service, janitorial, security services, parking lot attendants, home health care, health care aides, waste management, automotive repair services, landscaping, towing contracts, building and maintenance services, carpentry, clerical services, urban forestry, housekeeping, street maintenance and repair, and sidewalk maintenance and repair. This includes services performed on City-owned premises including the following City-owned locations: airports, parking lots, municipal parks, recreational facilities, and City-owned buildings. Contracts that are primarily for the purchase of goods or other property are not considered Service Contracts.

“Wage Theft” means a violation of the Ohio Prompt Pay Statute, RC 4113.15; the Ohio Minimum Fair Wage Standards Act, RC Chapter 4111; Oh. Const. Art. II, Sec. 34a; RC Chapters 4109 or 4115; RC 4113.17, 4113.18, 4113.52 or 4113.61; or a violation of any substantially equivalent federal or state law; as any of these laws may be amended or superseded.

**CHECK WHICHEVER IS APPLICABLE:**

(A) (  ) The undersigned person or entity HAS NOT had any Adverse Determinations within the last three (3) years.

(B) (  ) The undersigned person or entity HAS had any Adverse Determinations within the last three (3) years.

If (B) is checked, then in an attachment(s) to this form, please disclose all Adverse Determinations within the last three (3) years.

Name of Person or Entity: \_\_\_\_\_

Signature: \_\_\_\_\_

Printed Name of Signatory: \_\_\_\_\_

Title of Signatory: \_\_\_\_\_

Date: \_\_\_\_\_

**EQUAL OPPORTUNITY CLAUSE**  
**(Section 187.22(b) C.O.)**

Each Contract also shall contain the following equal opportunity clause:

"During the performance of this contract, the contractor agrees as follows:

- (1) The contractor shall not discriminate against any employee or applicant for employment because of race, religion, color, sex, sexual orientation, national origin, age, disability, ethnic group or Vietnam-era or disabled veteran status. The contractor shall take affirmative action to insure that applicants are employed and that employees are treated during employment without regard to race, religion, color, sex, sexual orientation, national origin, age, disability, ethnic group, or Vietnam-era or disabled veteran status. As used in this chapter, "treated" means and includes without limitation the following: recruited, whether by advertising or other means; compensated, whether in the form of rates of pay or other forms of compensation; selected for training, including apprenticeship, promoted, upgraded, demoted, downgraded, transferred, laid off and terminated. The contractor agrees to and shall post in conspicuous places, available to employees and applicants for employment, notices to be provided by the hiring representatives of the contractor setting forth the provisions of this nondiscrimination clause.
- (2) The contractor will, in all solicitations or advertisements for employees placed by or on behalf of the contractor, state that the contractor is an equal opportunity employer.
- (3) The contractor shall send to each labor union or representative of workers with which he has a collective bargaining agreement or other contract, or understanding, a notice advising the labor union or worker's representative of the contractor's commitments under the equal opportunity clause, and shall post copies of the notice in conspicuous places available to employees and applicants for employment.
- (4) It is the policy of the City that local businesses, minority-owned businesses and female-owned businesses shall have every practicable opportunity to participate in the performance of contracts awarded by the City subject to the applicable provisions of the Cleveland Area Business Code.
- (5) The contractor shall permit access by the Director or his or her designated representative to any relevant and pertinent reports and documents to verify compliance with the Cleveland Area Business Code, and with the Regulations. All such materials provided to the Director or designee by the contractor shall be considered confidential.
- (6) The contractor will not obstruct or hinder the Director or designee in the fulfillment of the duties and responsibilities imposed by the Cleveland Area Business Code.
- (7) The contractor agrees that each subcontract will include this Equal Opportunity Clause, and the contractor will notify each subcontractor, material supplier and supplier that the subcontractor must agree to comply with and be subject to all applicable provisions of the Cleveland Area Business Code. The contractor shall take any appropriate action with respect to any subcontractor as a means of enforcing the provisions of the Code."



**MAYOR'S OFFICE OF EQUAL OPPORTUNITY**  
**PARTICIPATION INFORMATION FORM**  
(Requirement and Standard Contracts)

The Subcontractor Participation Goals for this contract are:

**0% CSB Participation**

A searchable database of all CSB Subcontractors eligible to fulfill these subcontractor participation goals can be found on the City of Cleveland Office of Equal Opportunity Website:

<http://www.city.cleveland.oh.us/CityofCleveland/Home/Business/Equal%20Opportunity>

Click on [CSB/MBE/FBE Registry](#).



## DIVISION OF PURCHASES & SUPPLIES

### **Subcontractors Notice**

There is no Subcontractor Participation (Utilization) Goal for this contract. However, per Section A-19 or 22(a) of the Instructions to Bidders, any and all proposed subcontractors, whether City certified or not, must be divulged and listed in the sealed bid. If you do plan to utilize a subcontractor, submit a proposed subcontractor list on a separate, signed sheet of paper, listing the name, address, type of work or materials, and total subcontractor amount for each and every subcontractor that you propose to use on this contract.

You are encouraged to consider City-certified firms for any available subcontracting opportunities. A searchable database of all City-certified firms can be found on the City of Cleveland Office of Equal Opportunity Website:

<http://www.city.cleveland.oh.us/oeo>

On the website, click on CSB/MBE/FBE Registry.